

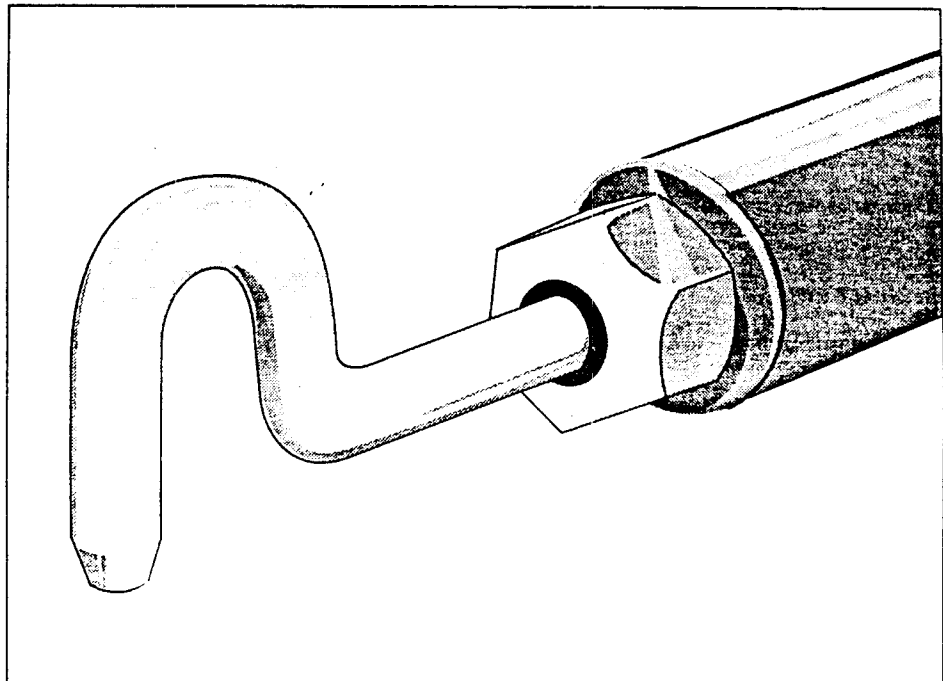

Environmental  
Programs

# ***Source Sampling for Particulate Pollutants***

***Student Workbook***  
*APTI Course 450*  
*Edition 3.0*





Environmental  
Programs

# ***Source Sampling for Particulate Pollutants***

***Student Workbook***

*Course 450*

*Edition 3.0*

Revised and edited by J.A. Jahnke, Ph. D.  
Source Technology Associates

Developed by North Carolina State University  
EPA Cooperative Assistance Agreement CT-901889

## Notice

This is not an official policy and standards document. The opinions and selections are those of the authors and not necessarily those of the Environmental Protection Agency. Every attempt has been made to represent the present state of the art as well as subject areas still under evaluation. Any mention of products or organizations does not constitute endorsement by the United States Environmental Protection Agency.

This project has been funded wholly or in part by the United States Environmental Protection Agency under Cooperative Assistance Agreement CT-902765 to North Carolina State University. It has been subjected to the Agency's peer review. The contents of this document do not necessarily reflect the views and policies of the Environmental Protection Agency, nor does mention of trade names or commercial products constitute endorsement or recommendation for use.

©1995 by North Carolina State University

All rights reserved, including the right of reproduction in whole or in part in any form. Authorization to photocopy items for internal or personal use, or the internal or personal use of specific clients, is granted by North Carolina State University, provided that the appropriate royalty fee is paid directly to the Copyright Clearance Center (CCC), 222 Rosewood Drive, Danvers, MA 01923. This consent does not extend to copying or transmission by any means—graphic or electronic—for any other purpose, such as for advertising or promotional purposes, for creating a new collective work, for resale, or for information storage and retrieval systems. For more information regarding appropriate royalty fees, contact the CCC, 508-750-8400.

Printed on recycled paper in the United States of America

ISBN 1-56049-023-3



# Contents

**Figures** .....ix

**Tables**.....x

**Introduction** ..... intro-1

    Course Goal ..... intro-1

    Course Objectives ..... intro-1

## **Lesson 1**

**Introduction to Source Sampling** ..... 1-1

        Lesson Goal ..... 1-1

        Lesson Objectives ..... 1-1

        Lesson Slides ..... 1-2

## **Lesson 2**

**Basic Principles** ..... 2-1

        Lesson Goal ..... 2-1

        Lesson Objectives ..... 2-1

        Lesson Slides ..... 2-2

## **Lesson 3**

**The Method 5 Sampling Train** ..... 3-1

        Lesson Goal ..... 3-1

        Lesson Objectives ..... 3-1

        Lesson Slides ..... 3-2

    First Day Laboratory Exercises

    Homework Review 1 ..... 3-9

        Question-and-Answer Session ..... 3-9

            Session Goal ..... 3-9

            Session Objectives ..... 3-9

## **Lesson 4**

**Isokinetic Source Sampling** ..... 4-1

        Lesson Goal ..... 4-1

        Lesson Objectives ..... 4-1

        Isokinetic Sampling ..... 4-2

**Lesson 5**

<b>Setting the Isokinetic Sampling Rate</b> .....	5-1
Lesson Goal .....	5-1
Lesson Objectives .....	5-1
Isokinetic Sampling Rate Derivation .....	5-5
Isokinetic Rate Equation Lecture Problem .....	5-5

**Lesson 6**

<b>Use of Computers and Programmable Calculators for Isokinetic Sampling</b> .....	6-1
Lesson Goal .....	6-1
Lesson Objectives .....	6-1
Lesson Slides .....	6-2

**Lesson 7**

<b>Methods 1-4</b> .....	7-1
Lesson Goal .....	7-1
Lesson Objectives .....	7-1
Lesson Slides .....	7-2
Second Day Laboratory Exercises	
Homework Review 2 .....	7-29
Question-and-Answer Session .....	7-29
Session Goal .....	7-29
Session Objectives .....	7-29

**Lesson 8**

<b>Calculation and Interpretation of Percent Isokinetic</b> .....	8-1
Lesson Goal .....	8-1
Lesson Objectives .....	8-1
Percent Isokinetic Derivation .....	8-1

**Lesson 9**

<b>Particulate Matter Sampling Train Configurations</b> .....	9-1
Lesson Goal .....	9-1
Lesson Objectives .....	9-1
Lesson Slides .....	9-2

**Lesson 10**

<b>Source Sampling Field Procedures</b> .....	10-1
Lesson Goal .....	10-1
Lesson Objectives .....	10-1
Getting Ready .....	10-2
On-site Activities .....	10-3
The Test .....	10-4
Post-test Activities .....	10-5

Sample Recovery - Probe/Nozzle.....	10-5
Sample Recovery - Filter .....	10-5
Sample Recovery - Wrap-up .....	10-5
Post-test Activities (cont.) .....	10-6
Sample Analysis - Impingers .....	10-6
Sample Analysis - Filters .....	10-6
Sample Analysis - Probe Wash .....	10-6
Post-test Activities .....	10-7
Final Calculations .....	10-7
Reporting .....	10-7
Third Day Laboratory Exercises	
Homework Review 3 .....	10-11
Question-and-Answer Session .....	10-11
Session Goal.....	10-11
Session Objectives.....	10-11

### **Lesson 11**

<b>Error Analysis</b> .....	11-1
Lesson Goal.....	11-1
Lesson Objectives.....	11-1
Lesson Slides .....	11-2

### **Lesson 12**

<b>Reporting in Units of the Standard</b> .....	12-1
Lesson Goal.....	12-1
Lesson Objectives.....	12-1
Lesson Slides .....	12-2

### **Lesson 13**

<b>Source Sampling Quality Assurance and Safety on the Sampling Site</b> .....	13-1
Lesson Goal.....	13-1
Lesson Objectives.....	13-1
Lesson Slides .....	13-2

### **Lesson 14**

<b>Literature Source</b> .....	14-1
Lesson Goal.....	14-1
Lesson Objectives.....	14-1
Periodicals .....	14-2
Professional Organizations.....	14-2
Publications .....	14-2
EMTIC Bulletin Board .....	14-2

## Lesson 15

<b>Advanced Topic Lecture</b> .....	15-1
Lesson Goal .....	15-1
Lesson Objectives .....	15-1

## Appendix A

<b>First Day Laboratory Exercises</b> .....	A-1
First Day Laboratory Exercise 1	
Traverse Point Determination.....	A-2
Laboratory Objective.....	A-2
Introduction .....	A-2
Procedures .....	A-2
Exercise 1 Hand-in Sheet .....	A-5
Number and Location of Traverse Points .....	A-5
Duplicate Exercise 1 Hand-in Sheet .....	A-7
First Day Laboratory Exercise 2	
Pitot Tube Calibration.....	A-9
Laboratory Objective.....	A-9
Introduction .....	A-9
Procedures .....	A-9
Exercise 2 Hand-in Sheet .....	A-13
Calibration of Type S Pitot Tube .....	A-13
Type S Pitot Tube Coefficient Data .....	A-13
Duplicate Exercise 2 Hand-in Sheet .....	A-15
First Day Laboratory Exercise 3	
Determination of Moisture Content by the Wet Bulb-Dry Bulb Technique....	A-16
Laboratory Objective.....	A-16
Introduction .....	A-16
Procedures .....	A-16
Wet Bulb-Dry Bulb Calculations.....	A-18
Exercise 3 Hand-in Sheet .....	A-23
Determination of Moisture Content by the	
Wet Bulb-Dry Bulb Technique .....	A-23
Duplicate Exercise 3 Hand-in Sheet .....	A-25
First Day Laboratory Exercise 4 .....	A-26
Calibration of the Orifice Meter - Determination of the $\Delta H_{\theta}$ .....	A-26
Laboratory Objective.....	A-26
Introduction .....	A-26
Procedures .....	A-27
Exercise 4 Hand-in Sheet .....	A-31
Calibration of the Orifice Meter and Determination of $\Delta H$ .....	A-31
Duplicate Exercise 4 Hand-in Sheet .....	A-33
Data Hand-in Sheet: First Day Laboratories .....	A-35
Duplicate Data Hand-in Sheet: First Day Laboratories .....	A-37

**Appendix B**

<b>Second Day Laboratory Exercise</b> .....	B-1
The Pitot Tube Traverse .....	B-2
Determination of the Flue Gas Velocity and Volumetric Flow Rate .....	B-2
Laboratory Objective .....	B-2
Introduction .....	B-2
Procedures .....	B-2
Calculations .....	B-4
Data Hand-In Sheet: Second Day Laboratory .....	B-7
The Pitot Tube Traverse and Determination of the Flue Gas Velocity and Volumetric Flow Rate .....	B-7
Duplicate Data Hand-In Sheet: Second Day Laboratory .....	B-9

**Appendix C**

<b>Third Day Laboratory Exercise</b> .....	C-1
The Method 5 Source Test .....	C-2
Sampling for Particulate Pollutants .....	C-2
Laboratory Objective .....	C-2
Introduction .....	C-2
Procedures: .....	C-5
Particulate Field Data Sheet .....	C-10
Method 5 Particulate Test Calculation Form .....	C-11
Data Hand-In Sheet: Third Day Laboratory .....	C-15
Method 5 Source Test Sampling for Particulate Pollutants .....	C-15
Duplicate Data Hand-In Sheet: Third Day Laboratory .....	C-17

**Appendix D**

<b>Homework Problems</b> .....	D-1
Problem Set 1 .....	D-2
Problem Set 1: Hand-in Sheet .....	D-3
Duplicate Problem Set 1: Hand-in Sheet .....	D-5
Problem Set 2 .....	D-6
Problem Set 2: Hand-in Sheet .....	D-9
Duplicate Problem Set 2: Hand-in Sheet .....	D-11
Problem Set 3 .....	D-12
Problem Set 3: Hand-in Sheet .....	D-15
Duplicate Problem Set 3: Hand-in Sheet .....	D-17

**Appendix E**

<b>Symbols</b> .....	E-1
Symbols Used for Variables in Methods 2-5 .....	E-2
Subscripts .....	E-2
Symbols and Units .....	E-2

**Appendix F**

**Equations Summary** ..... F-1

    Source-Sampling Equations for EPA Methods 2-5..... F-2

        Method 2 ..... F-2

        Method 4 ..... F-3

        Method 5 ..... F-3

**Appendix G**

**Conversion Factors** ..... G-1

# Figures

Figure 3-1.	Method 5 particulate sampling train .....	3-2
Figure 4-1.	100% isokinetic .....	4-2
Figure 4-2.	200% isokinetic .....	4-3
Figure 4-3.	50% isokinetic .....	4-3
Figure 6-1.	Nomograph .....	6-3
Figure 6-2.	Slide rule .....	6-3
Figure 6-3.	Calculator with removable memory chips .....	6-4
Figure 6-4.	Scientific calculator .....	6-4
Figure 6-5.	Computer .....	6-4
Figure 6-6.	Laptop computer .....	6-5
Figure 8-1.	Errors due to anisokinetic conditions .....	8-4
Figure A-1.	APTI course 450 sampling duct .....	A-2
Figure A-2.	Minimum number of traverse points for velocity (nonparticulate) traversers ..	A-3
Figure A-3.	Minimum number of traverse points for particulate traverses .....	A-3
Figure A-4.	Test arrangement for pitot tube calibration .....	A-9
Figure A-5.	Test arrangement for Type S pitot tube .....	A-10
Figure A-6.	Test arrangement for standard pitot tube.....	A-11
Figure A-7.	Test arrangement for wet bulb-dry bulb technique for moisture measurement .....	A-16
Figure A-8.	Equilibrium and inflection points of dry bulb and wet bulb thermometers .....	A-17
Figure A-9.	Arrangement for determining the static pressure, $P_s$ .....	A-18
Figure A-10.	Nomograph technique: percent moisture in flue gas .....	A-21
Figure A-11.	Using a psychrometric chart .....	A-22
Figure A-12.	Psychrometric chart expressing volume of water vapor by percent.....	A-22
Figure A-13.	Major internal components of the meter box.....	A-26
Figure C-1.	Method 5 particulate sampling train (with symbols) .....	C-3
Figure C-2.	Source Test Outline .....	C-4
Figure C-3.	Valve operation during leak check .....	C-6
Figure C-4.	Particulate field data sheet form .....	C-10
Figure D-1.	Sampling site .....	D-6
Figure F-1.	Method 5 particulate sampling train (with symbols) .....	F-5

# Tables

Table A-1.	Location of Traverse Points in Circular Stacks .....	A-4
Table A-2.	Saturated Water Vapor Pressure (Inches of Mercury) .....	A-20
Table F-1.	Method 2: Gas Velocity and Volumetric Flow Rate .....	F-2
Table F-2.	Method 4: Moisture Content of Stack Gas .....	F-3
Table F-3.	Method 5: Field Calculations.....	F-3
Table F-4.	Method 5: Report Calculations.....	F-4

Table G-1.	Temperature .....	G-2
Table G-2.	Length, Area, Volume .....	G-2
Table G-3.	Flow .....	G-2
Table G-4.	Mass, Pressure, Temperature, Concentration .....	G-3
Table G-5.	Viscosity .....	G-3
Table G-6.	Density .....	G-4



# ***Introduction***

## ***Course Goal***

The major goal of Course 450 is to provide you with a basic understanding of the theory and experimental methods involved in isokinetic sampling, the foundation of EPA Method 5. The course develops the ability to plan, guide, evaluate, and (after experience on the job) perform source sampling measurements to determine rates of particulate emissions from stationary sources.

Other goals of the course are for you to develop (a) a knowledge of the equipment employed, (b) an understanding of why the prescribed methods are used, and (c) the ability to perform the calibrations and calculations that are a part of the reference methods.

## ***Course Objectives***

After completion of this course, you should be able to:

- Describe the importance of source sampling in air pollution control agency programs.
- Define symbols and common terms used in source sampling.
- Recognize, interpret, and apply sections of the Code of Federal Regulations, Appendix A, pertinent to source sampling for particulate pollutants.
- Describe the construction, operation and calibration of the component parts of the Method 5 sampling train.
- Define isokinetic sampling and illustrate why it is important in sampling for particulate matter.
- Describe the "working" isokinetic rate equation and its derivation.
- Compute isokinetic sampling rates using a calculator.
- Apply EPA Reference Methods 1 through 4 in preparation for particulate sampling.
- Describe how the Type S pitot tube is constructed and standardized and how it is applied in source sampling.
- Determine the value of  $C_p$  for a Type S pitot tube.
- Recite the pitot tube equation from memory.
- Determine  $\Delta H_{\text{orifice}}$  for the Method 5 train orifice meter.
- Select sampling locations and traverse points using Method 1.

- Conduct a pitot tube traverse.
- Perform Method 3 gas analysis calculations for determining molecular weight and percent excess air.
- Determine moisture content using a wet bulb-dry bulb thermometer.
- List the steps involved in conducting a source test, including completion of pre-test and post-test forms. You should be able to recognize potential problem areas in preparing and conducting a source test.
- Properly assemble and leak-check a Method 5 sampling train.
- Calculate the percent isokinetic value for a source test, and interpret the effect of over- or under-isokinetic values on the source test results.
- Describe the difference between systematic error and precision as applied to source test measurements.
- List at least 10 aspects of the Method 5 sampling procedure that should be addressed in a source test quality assurance program.
- Describe the operation of the PM<sub>10</sub> sampling train.
- Describe at least one method that can be used to continuously monitor particulate mass emissions.

# **Lesson 1**

## ***Introduction to Source Sampling***

### ***Lesson Goal***

The goal of this lesson is to introduce you to the reasons why stacks and ducts of emission sources are sampled for particulate and gaseous pollutants, and to review the basic categories of source sampling methods.

### ***Lesson Objectives***

Upon completion of this lesson, you should be able to:

1. Discuss the health effects associated with particulate matter in the ambient air.
2. List the principle sources of particulate air pollutants.
3. Identify the federal documents in which source emission regulations and testing methods can be found.
4. Describe four standards used for regulating emissions from stationary sources.
5. Describe three techniques that can be used to measure the emission of particulate matter and pollutant gases from stationary sources.
6. Describe the uses of Methods 1-9.

# Lesson 1

## Course 450

Introduction to Method 5

01-01

### Particles

Small, discrete masses of solid or liquid matter

Examples: dust, smoke, mist, and fly ash

01-02

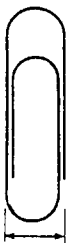
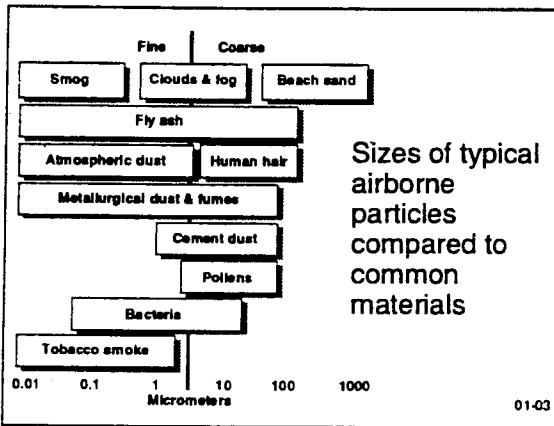

10,000  $\mu\text{m}$

It would take 10,000 particles, each 1 micrometer ( $\mu\text{m}$ ) in diameter, laid end to end, to stretch across the width of a small paper clip.

01-04

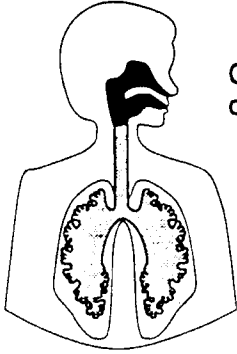

**Particles > 10  $\mu\text{m}$**   
Collect in upper part of respiratory system

01-05

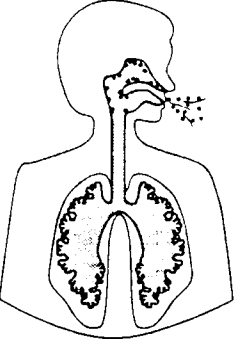

Particles collect moisture as they move through moist air of upper respiratory region, making them heavier and causing them to strike walls of throat, nose, etc.

They are eliminated by sneezing, coughing, nose blowing, spitting, or by the digestive system.

01-06

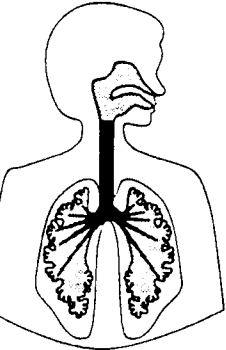

**Particles 1-10  $\mu\text{m}$**   
Collect in middle part of respiratory system—the tracheobronchial region

01-07

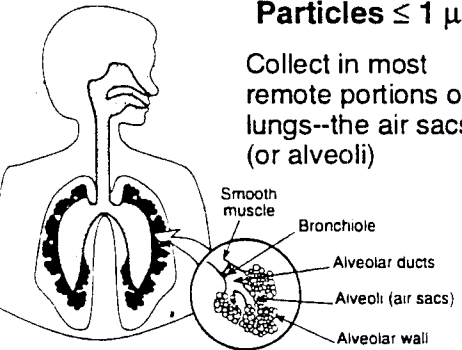

**Particles  $\leq 1 \mu\text{m}$**   
Collect in most remote portions of lungs—the air sacs (or alveoli)

Smooth muscle  
Bronchiole  
Alveolar ducts  
Alveoli (air sacs)  
Alveolar wall

01-08

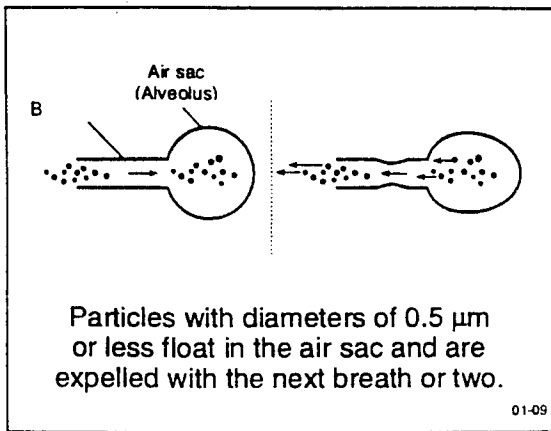

Health Effects - Nontoxic Particles	
Concentration of Particles in $\mu\text{g}/\text{m}^3$	Effect
2000 $\mu\text{g}/\text{m}^3$ with 0.4 ppm $\text{SO}_2$ (24-hr avg) episodes of several days duration	Increase in deaths due to bronchitis
1000 $\mu\text{g}/\text{m}^3$ with 0.25 ppm $\text{SO}_2$ (24-hr avg) during episodes	Increase in mortality from all causes including respiratory and cardiac disease
300 $\mu\text{g}/\text{m}^3$ with 0.21 ppm $\text{SO}_2$ (annual avg)	Significant increase in bronchitis symptoms
130 $\mu\text{g}/\text{m}^3$ with $\text{SO}_2$ (annual avg)	Increase in frequency and severity of lower respiratory illness
100-200 $\mu\text{g}/\text{m}^3$ with 0.05 to 0.08 ppm $\text{SO}_2$ (avg seasonal levels)	Increase in incidences of bronchitis reported above this level

01-10

- ### Emission Generation Categories
- Transportation
  - Stationary source fuel combustion
  - Industrial processes
  - Solid waste disposal
  - Miscellaneous
- 01-11

- ### Stationary Combustion Sources
- Produce energy but no other products. Emissions result from fuel combustion.
- Fixed energy generating sources range in size from home heating furnaces to major power plants.
  - Sources include commercial, institutional, industrial, and steam-electric power plants.
  - Fuels used include coal, oil, natural gas, and wood. Other fuels such as liquefied natural gas, propane, process gas, etc. may also be used.
- 01-12

### Industrial Processes

Emit pollutants in the course of manufacturing products

- Major sources include chemical processing, food and agricultural industries, metallurgical and mineral product factories, petroleum refining, petrochemical plants, petroleum storage, and wood-processing industries.
- Smaller sources include painting, dry-cleaning, and degreasing operations.

01-13

### Solid Waste Disposal

Facilities that dispose of unwanted products and by-products. Emissions result from the disposal process --usually burning.

01-14

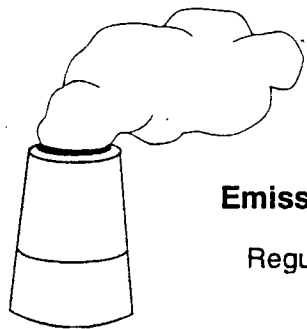

### Emission Standards

Regulations in force

01-15

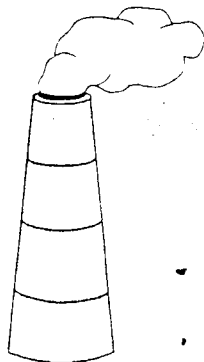

### Emission Standard

A regulation that sets:

- Rate of emissions
- Level of opacity
- Equipment or fuel specifications
- Other measures

01-16

### **Stationary Source Regulations**

- Largest and most varied class of regulations
- General
- By source category
- Source-specific

01-17

### **Inspection/Testing/ Obtaining Information**

Require record-keeping by sources

- Emissions data
- Process data

Perform inspections

Conduct emissions testing

01-18

### **Federal Register System**

Basic means of proposing and promulgating federal administrative regulations/decisions

- Daily Federal Register
- Code of Federal Regulations

01-19

### **Daily Federal Register**

Issued every working day

Contains:

- Proposed rules
- Rules and regulations
- Notices
- Proclamations, executive orders, etc.
- 55 FR 47471 (11/14/90)

01-20



### Code of Federal Regulations

Annual compilation of all administrative regulations

Organized by:

- Title
- Chapter
- Subchapter
- Part
- Section

40 CFR 60 Appendix A

01-21

### Emission Standards for Sources

- Concentration of stack gas ( $c_s$ )
- Pollutant mass rate (pmr)
- Emission rate ( $E$ )
- Process weight rate ( $E$ )

01-22

### Concentration of Stack Gas ( $c_s$ )

Can be expressed in:

- ppm
- g/dscm
- gr/dscf

01-23

### For example:

The New Source Performance Standards (NSPS) for asphalt concrete plants is:

0.04 gr/dscf  $\Leftrightarrow$  90 mg/dscm.

01-24

### Pollutant Mass Rate (pmr)

Can be expressed in:

- lb/hr
- g/hr

01-25

pmr = Concentration x Stack gas  
volumetric  
flow rate

$$= \frac{\text{lb}}{\text{dscf}} \times \frac{\text{dscf}}{\text{hr}}$$

$$= \frac{\text{lb}}{\text{hr}}$$

01-26

### Emission Rate (E)

Can be expressed in:

- lb/10<sup>6</sup> Btu heat input
- ng/joule heat input

01-27

$$E = \frac{\text{Pollutant mass rate}}{\text{Heat input rate}}$$

$$= \frac{\text{lb/hr}}{10^6 \text{ Btu/hr}}$$

$$= \frac{\text{lb}}{10^6 \text{ Btu}}$$

01-28

**For example:**

The NSPS emission rate for fossil-fuel fired steam generators (FFSG) is:  
 particulate emissions limited to  
 0.03 lb/10<sup>6</sup> Btu.

01-29

**Process Weight Rate (E)**

Can be expressed in:

- lb/tons of product
- kg/metric tons of product

01-30

**For example:**

The NSPS for sulfuric acid plants is:  
 SO<sub>2</sub> emissions limited to 2 kg  
 SO<sub>2</sub>/metric ton H<sub>2</sub>SO<sub>4</sub> produced.

01-31

$$\text{Combustion} = \frac{\text{Pollutant mass rate}}{\text{Heat input rate}}$$

$$\text{Process} = \frac{\text{Pollutant mass rate}}{\text{Item or mass process rate}}$$

01-32

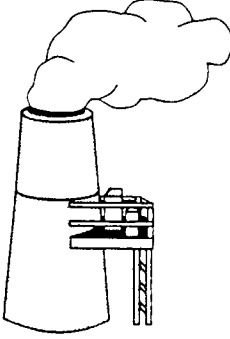

**Measurement of Source Pollutant Emissions**

01-33

**Methods for Measuring Emissions**

Manual sampling

Continuous monitoring

- Extractive
- In-situ

Remote sensing

01-34

**EPA Reference Methods**

- Used for source compliance testing
- Describe actual testing procedure
- Found in Code of Federal Regulations

01-35

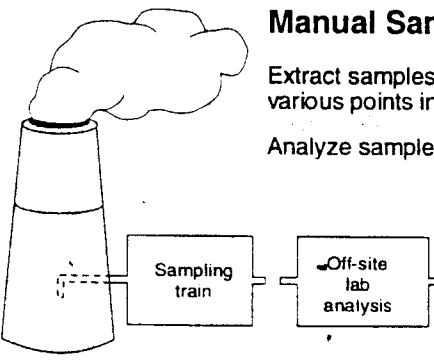

**Manual Sampling**

Extract samples from various points in stack.

Analyze samples in lab.

01-36

### Methods 1 - 4

Used in other reference methods

Used to determine:

- Number of sampling points (Method 1)
- Stack gas velocity (Method 2)
- Stack gas molecular weight (Method 3)
- Stack gas moisture content (Method 4)

01-37

### Method 1

Selection of traverse points

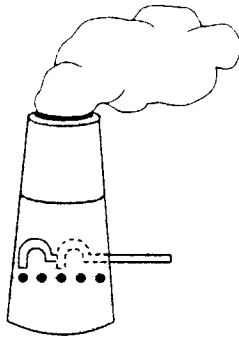

01-38

### Method 2

Determination of stack gas velocity and volumetric flow rate (using Type S pitot tube)

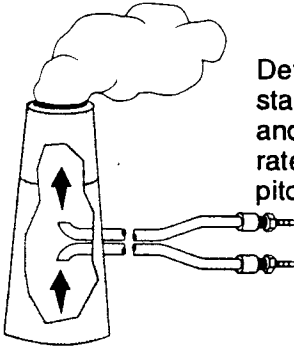

01-39

### Method 3

Determination of the dry molecular weight of flue gas (using Orsat apparatus measuring %O<sub>2</sub>, %CO<sub>2</sub>, and %CO)

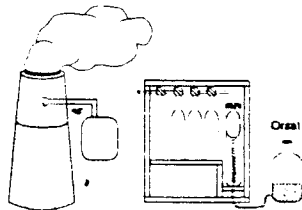

01-40

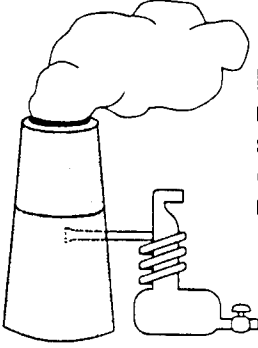

**Method 4**

Determination of moisture content of stack gas (by condensation method)

01-41

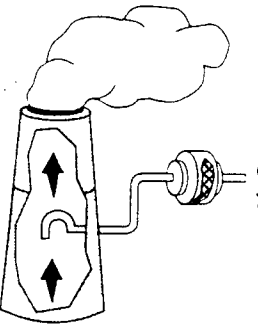

**Method 5**

Sampling method for particulate matter (isokinetic collection of particles on a filter)

01-42

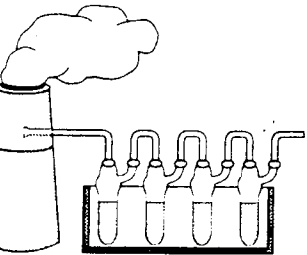

**Method 6**

Sampling and analytic method for determining SO<sub>2</sub> emissions (barium-thorin titration)

01-43

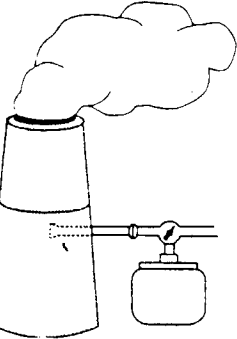

**Method 7**

Determination of NO<sub>x</sub> emissions (colorimetric phenoldisulfonic acid method)

01-44

**Method 8**

Determination of  $H_2SO_4$  mist and  $SO_2$  emissions (intended for  $H_2SO_4$  plants)

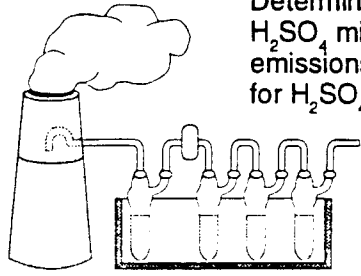

01-45

**Method 9**

Determination of stack plume opacity (by visual observation)

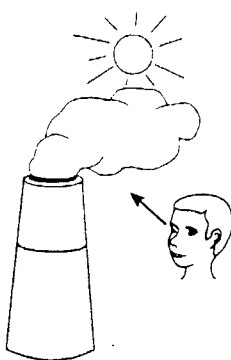

01-46

Method 10	Determination of CO
Method 11	Determination of hydrogen sulfide
Method 12	Determination of inorganic lead emissions
Method 13, 14	Determination of fluorides
Method 15	Determination of $H_2S$ , COS, $CS_2$
Method 16	Determination of total reduced sulfur (TRS)
Method 17	Determination of particulates (in-stack filtration method)

01-47





# **Lesson 2**

## **Basic Principles**

### **Lesson Goal**

The goal of this lesson is to introduce you to the basic science that underlies the particulate source test methods, including concepts of gas physics and the symbols and formulas that must be understood to comprehend the course material.

### **Lesson Objectives**

Upon completion of this lesson, you should be able to:

1. Define the symbols and common source sampling expressions used in the course.
2. Write the expressions for absolute temperature and absolute pressure.
3. Explain what molecular weight is and how it relates to the number of moles of a compound.
4. Write the Ideal Gas Law equation and describe the effects of changing pressure and temperature on a gas volume.
5. Recognize the form of an Ideal Gas Law correction equation.
6. Recognize the pitot tube equation on sight and understand the relative importance of the parameters in the equation. (Note: You will be required to memorize this equation.)
7. Explain what parameter must be measured in order to determine a pollutant mass rate.

## Lesson 2

Course 450  
Basic Principles

02-01

### Temperature

Degrees Fahrenheit: °F

Degrees Centigrade: °C

$$^{\circ}\text{C} = 5/9 (^{\circ}\text{F} - 32)$$

$$^{\circ}\text{F} = 9/5 (^{\circ}\text{C}) + 32$$

02-02

### Absolute Temperature

Degrees Rankine: °R

Degrees Kelvin: °K

$$^{\circ}\text{R} = ^{\circ}\text{F} + 459.49$$

$$^{\circ}\text{K} = ^{\circ}\text{C} + 273.16$$

02-03

### Absolute Pressure, P

$$P = P_b + p_g$$

$P_b$  = Barometric pressure

$p_g$  = Gauge pressure

02-04

### Units of Pressure

in. Hg    atmospheres

mmHg    torr

in. H<sub>2</sub>O    pascals

02-05

### Conversions

1 in. Hg = 13.6 in. H<sub>2</sub>O

02-06

### 1 Atmosphere =

29.92 in. Hg

39.90 ft H<sub>2</sub>O

14.70 lbs/in.<sub>2</sub>

760 mmHg

02-07

### EPA Standard Pressure and Temperature

$P_{std}$  = 29.92 in. Hg

$t_{std}$  = 20° C or 68° F

02-08

### Atomic Weight

A number that indicates how heavy (on the average) an atom is compared to an atom of another element

(Assign carbon atomic wt = 12)

02-09

### Molecular Weight, M

The sum of the atomic weights of all the atoms in a molecule

02-10

**n = number of moles**  
**1 mole =**

The molecular weight of a compound expressed in lbs (lb-mole) or in grams (g-mole)

02-11

**1 gram-mole =**

$6.023 \times 10^{23}$  molecules

(Avogadro's Number)

02-12

**An Avogadro's Number  
worth of gas molecules**

$$(6.023 \times 10^{23})$$

**occupies**

22.4 L

at 0° C and 1 atmosphere

02-13

**Given a mass, m, of a  
compound, the number of  
moles is calculated by:**

$$n = \frac{m}{M}$$

02-14

**The Ideal Gas Law**

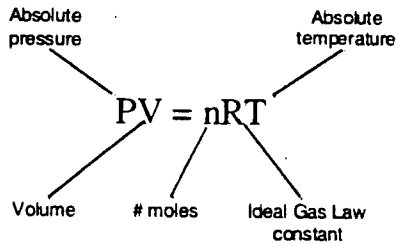

02-15

**R**

The gas law constant is dependent on  
units used for EPA reference methods  
in English units:

$$R = 21.83 \frac{(\text{in. Hg})(\text{ft}^3)}{(\text{lb-mole})(^\circ\text{R})}$$

02-16

### Correcting Volume to Standard Conditions

$$V_s = nR \frac{T_s}{P_s}$$

$$V_{std} = nR \frac{T_{std}}{P_{std}}$$

$$V_{std} = V_s \frac{T_{std} P_s}{P_{std} T_s}$$

02-17

### Moving Gases

- Velocity
- Volumetric flow rate
- Pollutant mass rate

02-18

### Velocity

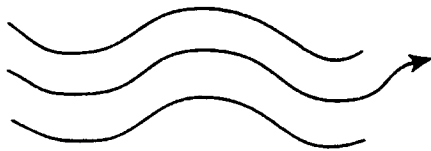

$$v_s = \text{ft/sec or ft/hr}$$

02-19

Velocity,  $v_s$ ,  $\frac{\text{ft}}{\text{sec}}$ ,  $\frac{\text{ft}}{\text{hr}}$

Determined by Method 2 using the Type S pitot tube

02-20

### The Pitot Tube Equation

$$v_s = K_p C_p \sqrt{\frac{T_s \Delta P}{P_s M_s}}$$

02-21

### Volumetric Flow Rate

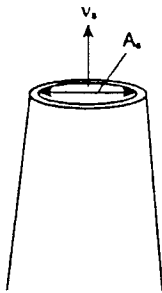

$$Q_s = v_s A_s$$

$$\frac{\text{ft}^3}{\text{sec}} = \frac{\text{ft}}{\text{sec}} \times \text{ft}^2$$

or

$$\frac{\text{ft}^3}{\text{hr}} = \frac{\text{ft}}{\text{hr}} \times \text{ft}^2$$

02-22

### Pollutant Mass Rate

$\text{pmr}_s$

$$\text{pmr}_s = c_s Q_s$$

Where:  $c_s$  = the pollutant concentration

02-23

### Concentration, $c_s$

$$c_s = \frac{m}{V} = \frac{\text{Quantity of pollutant (mass)}}{\text{Quantity of effluent gas (vol)}}$$

Units:  $\text{g/m}^3$ ,  $\text{lbs/ft}^3$ ,  $\text{gr/ft}^3$ , ppm

Note: 7000 grains (gr) = 1 lb

02-24

$$\text{pmr}_s = c_s Q_s$$

$$\frac{\text{lbs}}{\text{hr}} = \frac{\text{lbs}}{\text{ft}^3} \times \frac{\text{ft}^3}{\text{hr}}$$

02-25

**Emission Rate  
(Combustion Sources)**

$$E = \frac{\text{pmr}_s}{Q_H} \left( \frac{\text{lbs}}{10^6 \text{ Btu}} \right)$$

Where:  $Q_H$  = heat input rate in units  
of  $10^6$  Btu/hr

02-26



# **Lesson 3**

## ***The Method 5 Sampling Train***

### ***Lesson Goal***

The goal of this lesson is to familiarize you with the equipment used for Method 5 particulate sampling and to discuss construction details of the apparatus.

### ***Lesson Objectives***

Upon completion of this lesson, you should be able to:

1. Identify the basic components of the Method 5 sampling train.
2. Describe the design and construction criteria for the sampling nozzle.
3. Describe the design and construction criteria for the pitot tube.
4. Describe how a sample probe is constructed and the advantages and disadvantages of different probe liner materials.
5. List the sampling train components that are contained in the sample box and describe how they are assembled.
6. Describe how an umbilical line is constructed.
7. List the sampling train components that are contained in the meter box and describe how they are assembled in the box.

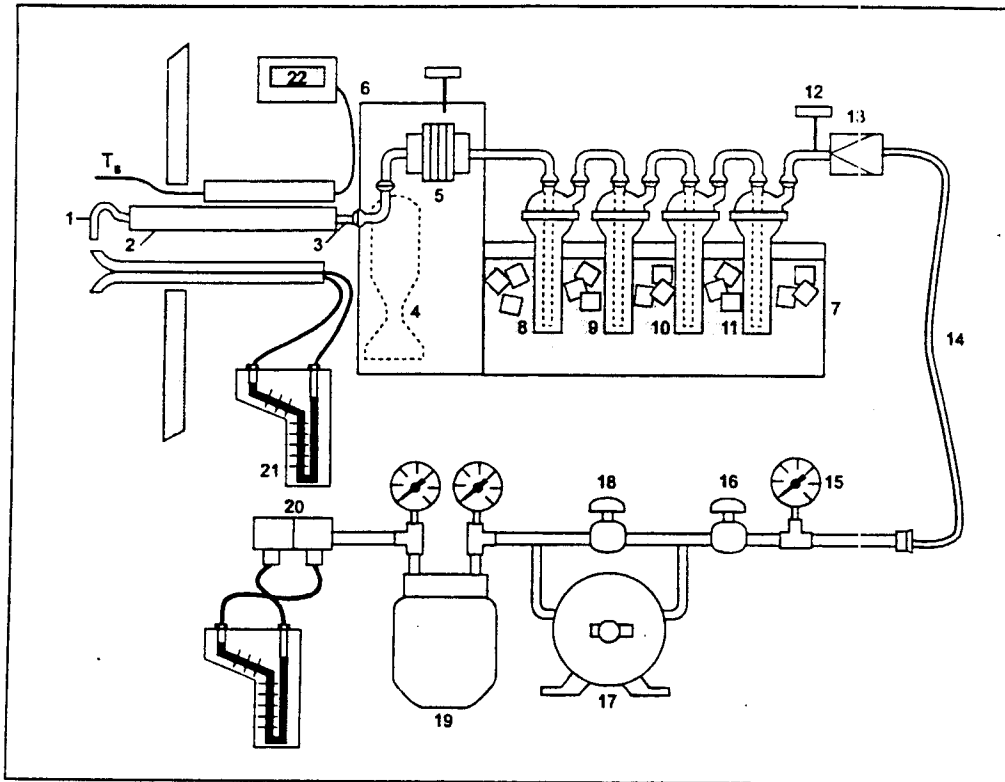

Figure 3-1. Method 5 particulate sampling train

## Lesson 3

### Course 450

The Method 5 Sampling Train

03-01

### Sampling Train Components

- The probe assembly
- The sample box
- The umbilical
- The meter box

03-02

### The Probe Assembly

- Nozzle
- Pitot tube
- Thermocouple
- Probe liner
- Probe sheath

03-03

### Sampling Nozzle

- Stainless steel seamless tubing
- Buttonhook or elbow design
- Wide range of nozzle diameters
- Calibration with micrometer to nearest 0.001 in. internal diameter
- Repair or replace nicked, dented or corroded nozzles

03-04

### The Pitot Tube

- Usually Type S
- Nozzle entry plane must be even with pitot orifice
- Centerline of orifice and nozzle must agree
- Minimum separation of 1.9 cm
- Geometry of pitot, probe sheath, and thermocouple important

03-05

### Probe Sheath

- Usually stainless steel
- Pitot tube welded to sheath to prevent misalignment
- Protects liner from breakage

03-06

### Probe Liner

Borosilicate or quartz glass

Heating system to maintain exit gas temperature of 120° C

Borosilicate temperature to 480° C

Quartz glass temperature to 900° C

03-07

### The Sample Box

#### Heated Filter Box

- Heating element to maintain filter temperature of 120° C
- Filter holder
- Flexibility for vertical and horizontal traverses
- Insulated

#### Impinger Box

- Provide support and protection for glassware
- Insulated
- Holding container for ice to cool impingers

03-08

### The Umbilical Line

- Sample lines
- Pitot lines
- Electrical connections
- Covered in a protective sheath

03-09

### The Meter Box

- Pump
- Dry gas meter
- Inclined manometers for  $\Delta p$  and  $\Delta H$  readings
- Flow control valves
- Thermocouple readouts
- Ports for integrated gas sampling

03-10

# ***First Day Laboratory Exercises***

Your Course Director will break the class up into groups that will perform the laboratory exercises together during the course. On the first day, you will be performing four different exercises that relate to Methods 1-4. The laboratory exercise directions are given on page A-1 of Appendix A (Laboratory Exercises).

Take notes here for background information and any special instructions given by the Course Director or Laboratory Instructors.

## Notes

## Notes



# **Homework Review 1**

## **Question-and-Answer Session**

### **Session Goal**

The goal of this session is to review homework problems assigned on Day 1 and to provide you with the opportunity to discuss any questions or issues presented in the previous day's sessions.

### **Session Objectives**

After completing this review, you will be able to do the following:

1. Meet the goals and objectives of yesterday's sessions.
2. Perform calculations similar to those provided in the Homework Exercise.

## Notes

## Notes

## Notes

# **Lesson 4**

## ***Isokinetic Source Sampling***

### ***Lesson Goal***

The goal of this lesson is to present the concept of isokinetic sampling, providing the rationale of why it is necessary to sample isokinetically for particulate matter.

### ***Lesson Objectives***

Upon completion of this lesson, you should be able to:

1. Define isokinetic sampling.
2. Describe how small and large particles behave in a moving gas stream.
3. Discuss the effect of over-isokinetic sampling on the measured particulate matter concentration.
4. Discuss the effect of under-isokinetic sampling on the measured particulate matter concentration.

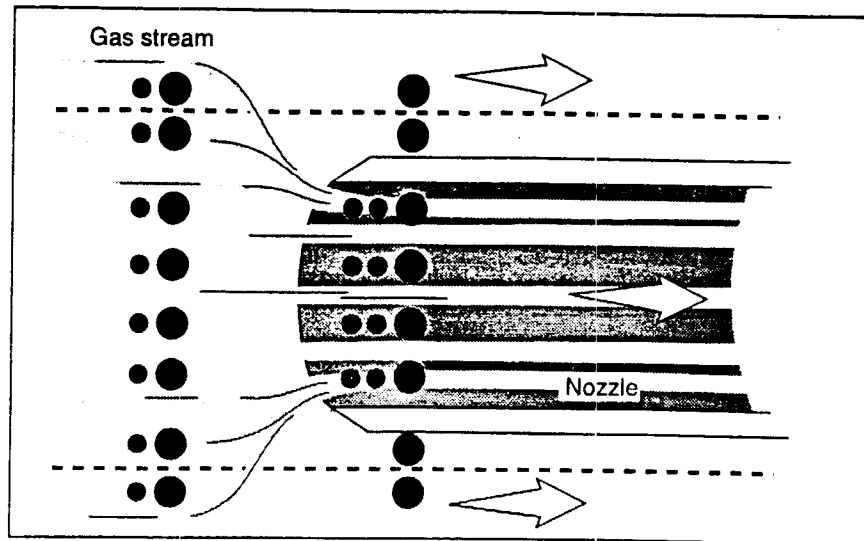

Figure 4-2. 200% isokinetic

Assume:  $v_n = 2v_s$   
 $Q_n = 2 \text{ cfm}$   
 4 large and 8 small particles collected/minute

Therefore:  $\text{mass/minute} = 4 \times 6 + 8 \times 0.03 = 24.2 \text{ m.u./minute}$

$$c_n = \frac{24.2 \text{ m.u./min}}{2 \text{ ft}^3\text{min}} = 12.1 \frac{\text{m.u.}}{\text{ft}^3}$$

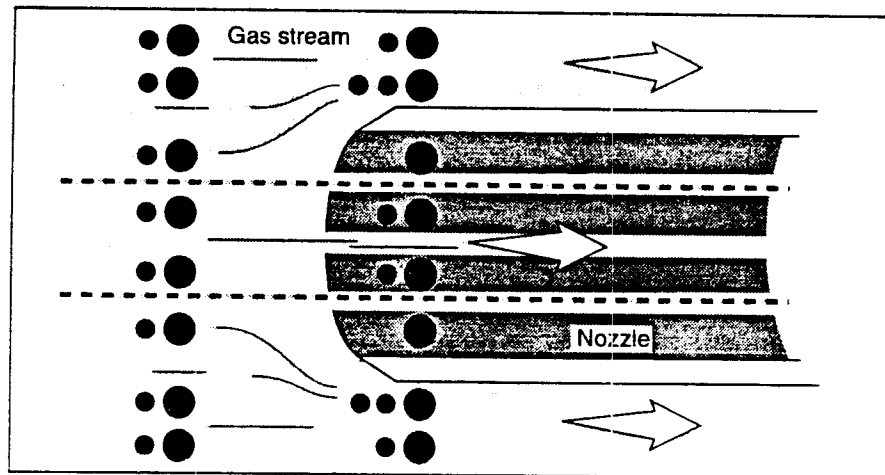

Figure 4-3. 50% isokinetic

Assume:  $v_n = 1/2v_s$   
 $Q_n = 1/2 \text{ cfm}$   
 4 large and 2 small particles collected/minute

# Lesson 5

## Setting the Isokinetic Sampling Rate

### Lesson Goal

The goal of this lesson is to derive the isokinetic rate equation for the Method 5 sampling train, from basic principles of the Ideal Gas Law, and to present methods for its solution.

### Lesson Objectives

Upon completion of this lesson, you should be able to:

1. Calculate the basic equation for establishing the isokinetic rate,  $\Delta H = K\Delta p$ .
2. Describe how gas passing through the sampling train undergoes changes of moisture content, temperature, and pressure.
3. Describe how the isokinetic rate equation is derived from the requirement that  $v_n = v_s$ , and that the final expression is obtained by substituting the pitot tube equation and orifice meter equation and by correcting for pressure, temperature, and moisture content.
4. Recognize the fact that a separate equation exists for the calculation of the nozzle diameter and that the "actual" nozzle diameter, not the "calculated" diameter is used in subsequent calculations.
5. Calculate the value of  $D_n$ , the nozzle diameter, given the appropriate input data, using a hand-held calculator.
6. Calculate the value of  $K$  and  $\Delta H$ , given the appropriate input data, using a hand-held calculator.

6. Flow Rate Corrected for T, P and Moisture

$$Q_n = \frac{1}{1 - B_{ws}} \frac{T_s P_m}{T_m P_s} Q_m \quad (5-6)$$

7. Relation of Flow Rate at Nozzle to Meter Flow Rate - Substituting for  $Q_m$   
(Eq. 5-3 into Eq. 5-6)

$$Q_n = \frac{1}{(1 - B_{ws})} \frac{T_s P_m}{T_m P_s} K_m \sqrt{\frac{T_m \Delta H}{P_m M_m}} \quad (5-7)$$

8. Substituting for  $Q_n$   
(Eq. 5-2 into Eq. 5-7)

$$\frac{\pi D_n^2}{4} v_s = \frac{1}{(1 - B_{ws})} \frac{T_s P_m}{T_m P_s} K_m \sqrt{\frac{T_m \Delta H}{P_m M_m}} \quad (5-8)$$

9. Pitot Tube Equation

$$v_s = K_p C_p \sqrt{\frac{T_s \Delta p}{P_s M_s}} \quad (5-9)$$

10. 
$$\frac{\pi D_n^2}{4} K_p C_p \sqrt{\frac{T_s \Delta p}{P_s M_s}} = \frac{1}{(1 - B_{ws})} \frac{T_s P_m}{T_m P_s} K_m \sqrt{\frac{T_m \Delta H}{P_m M_m}} \quad (5-10)$$

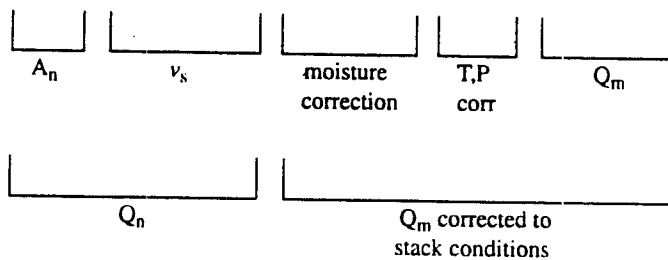

11. Solving for  $\Delta H$

$$\Delta H = \left\{ D_n^4 \left( \frac{\pi K_p C_p}{4 K_m} \right)^2 \frac{(1 - B_{ws})^2 M_m T_m P_s}{M_s T_s P_n} \right\} \Delta p \quad (5-11)$$



15. Simplified Isokinetic Rate Equation

$$\Delta H = K\Delta p \quad (5-15)$$

To use this equation for setting the isokinetic sampling rate, note the  $\Delta p$  from the pitot tube manometer. Multiply  $\Delta p$  times the calculated K value to obtain  $\Delta H$ . Then, adjust the fine control knob on the meter box until the  $\Delta H$  value is read on the orifice meter manometer.

## **Notes**

# **Lesson 6**

## ***Use of Computers and Programmable Calculators for Isokinetic Sampling***

### ***Lesson Goal***

The goal of this lesson is to present the options available for performing field calculation of the isokinetic rate equation.

### ***Lesson Objectives***

Upon completion of this lesson, you should be able to:

1. Describe what a source sampling nomograph is and why it is used in the field.
2. Describe the assumptions used in the source test nomograph.
3. Identify a source test slide rule and describe how it can be used in source testing.
4. Describe how a hand-held calculator with magnetic card or unerasable memory may be used in performing the source test field calculations.
5. Discuss how a personal computer, portable or other, can be used in performing source test field calculations.
6. Outline at least one possible algorithm that could be used for source test calculations when applying a personal computer.
7. List advantages and disadvantages of using computers in source test field calculations.

- Nomograph
- Slide rule calculators
- Simple calculators
- Programmable calculators (scientific, card read)
- Programmable calculators (continuous memory)
- Computers (desktop)
- Portable computers/notebooks

06-05

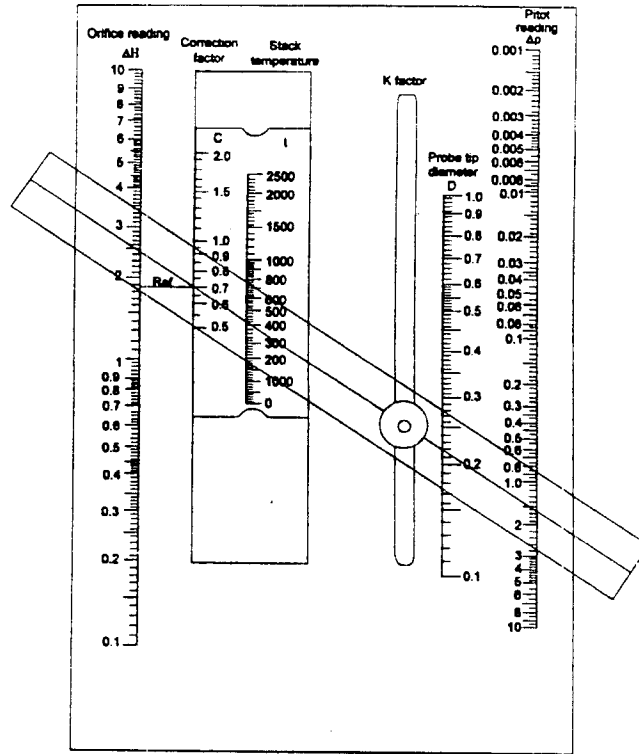

Figure 6-1. Nomograph

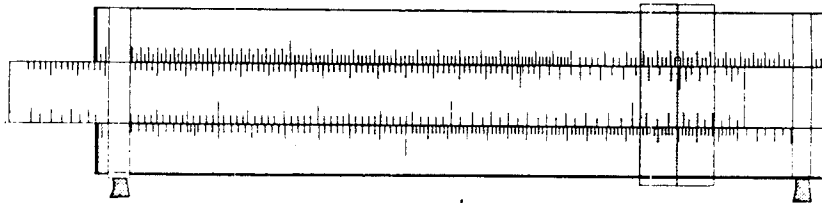

Figure 6-2. Slide rule

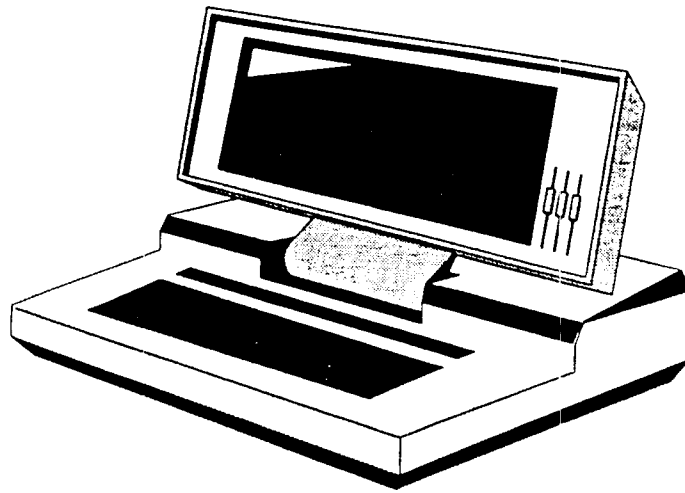
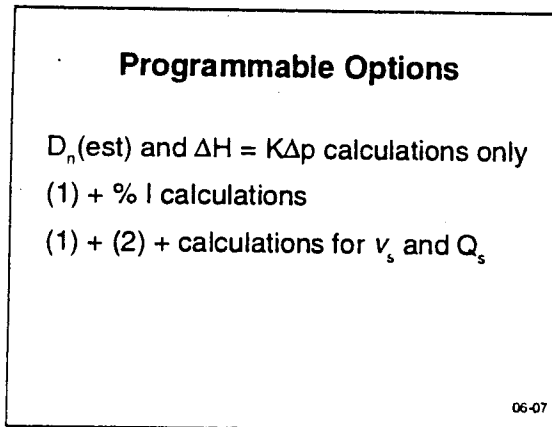
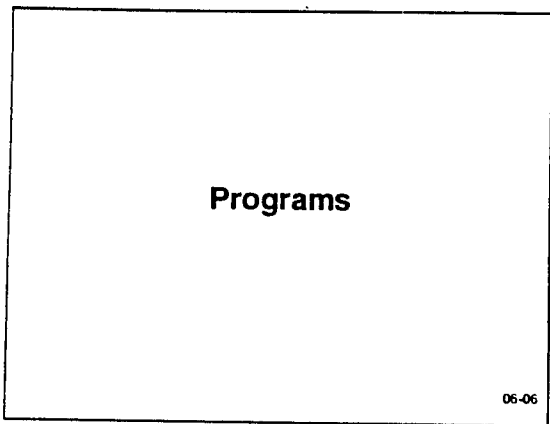

Figure 6-6. Laptop computer



### Other Options

- Methods 1, 2, 3, 4 calculations
- Report programs - print-out of results
- Field cross-check programs
- Fancy graphics - displays

06-08

### Published Programs

#### Calculator

- TI-59 EPA 450/2-83-006
- HP-41 EPA 340/1-85-018
- HP-65 EPA 600/8-76-002

#### Programs in Basic

- See EMTIC bulletin board

06-09

## Isokinetic Sampling

Isokinetic sampling conditions exist when the velocity of the gas entering the probe nozzle tip ( $v_n$ ) is exactly equal to the velocity of the approaching stack gases ( $v_s$ ), that is  $v_n = v_s$ . The percent isokinetic is defined as:

$$\% \text{ isokinetic} = \frac{v_n}{v_s} \times 100$$

and is equal to 100% only when  $v_n = v_s$ . When  $v_n \neq v_s$  (anisokinetic conditions), sample concentrations can be biased due to the inertial effects of particles.

If the gas-flow streamlines are disturbed as in anisokinetic conditions:

1. Large particles tend to move in the same initial direction.
2. Small particles tend to follow the streamlines.
3. Intermediate particles are somewhat deflected.

As an example, assume that we have a large particle of 6 mass units (m.u.) and a small particle of 0.03 mass units. Consider the following situations:

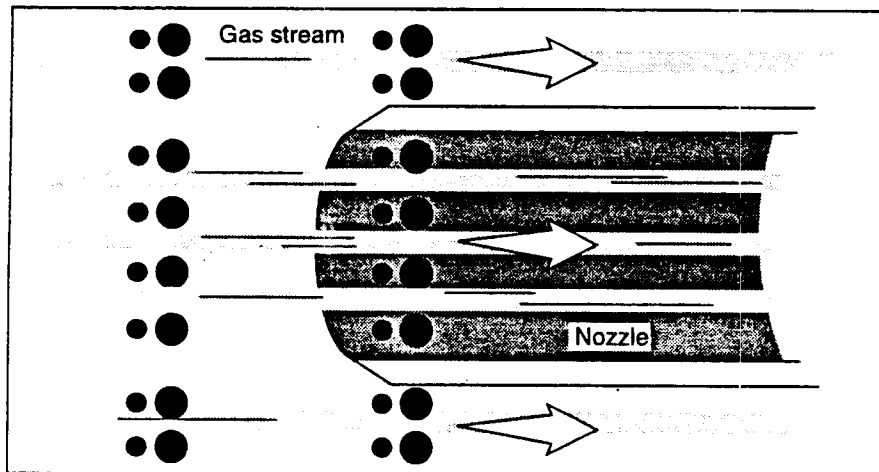

Figure 4-1. 100% isokinetic

Assume:  $v_n = v_s$   
 $Q_n = 1 \text{ cfm}$   
 4 large and 4 small particles are collected/minute

Therefore: mass/minute =  $4 \times 6 + 4 \times 0.03 = 24.1 \text{ m.u./minute}$

$$c_n = \frac{24.1 \text{ m.u./min}}{1 \text{ ft}^3 \text{ min}} = 24.1 \frac{\text{m.u.}}{\text{ft}^3}$$

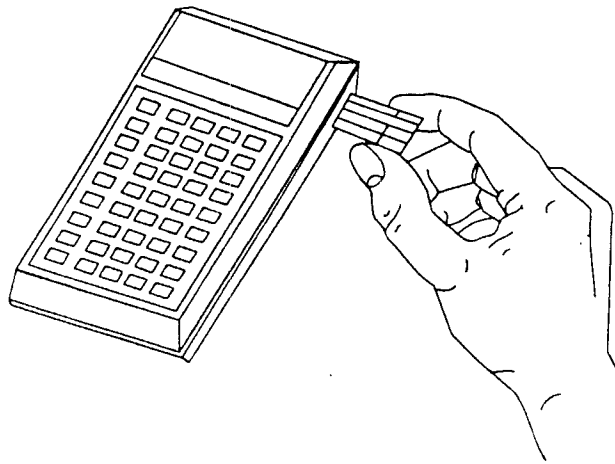

Figure 6-3. Calculator with removable memory chips

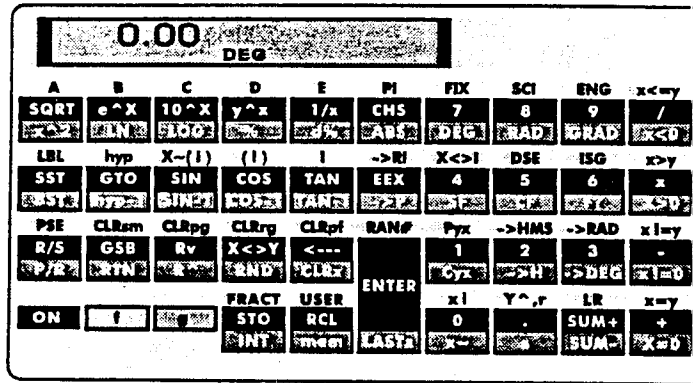

Figure 6-4. Scientific calculator

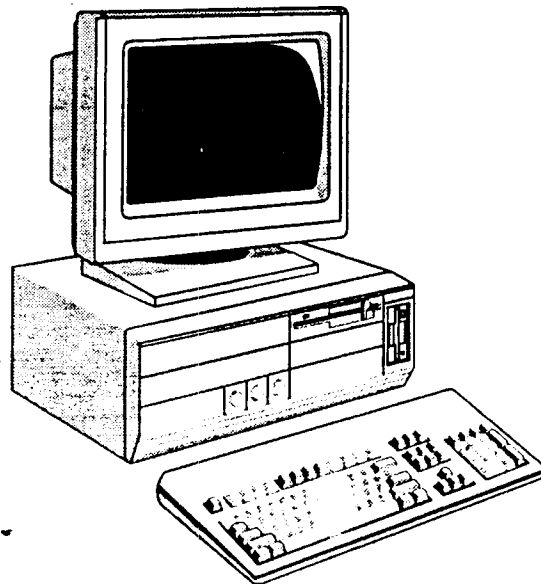

Figure 6-5. Computer



Therefore: mass/minute =  $4 \times 6 + 2 \times 0.03 = 24.1$  m.u./minute

$$c_n = \frac{24.1 \text{ m.u./min}}{1/2 \text{ ft}^3\text{min}} = 48.2 \frac{\text{m.u.}}{\text{ft}^3}$$

## Lesson 6

### Course 450

Use of Computers and Programmable  
Calculators for Isokinetic Sampling

06-01

### The Basic Calculations

$$D_{n(\text{est})} = \frac{0.0358 Q_m P_m \sqrt{T_s M_s}}{\sqrt{T_m C_p (1 - B_{ws(\text{est})})} \sqrt{P_s \Delta P_{\text{est}}}}$$

$$\Delta H = \left\{ 846.72 D_n^4 \Delta H_{\phi} C_p^2 (1 - B_{ws})^2 \frac{M_d T_m P_s}{M_k T_s P_m} \right\}$$

06-02

### The Basic Calculations

$$\Delta H = K \Delta p$$

$$T_s = t_s + 460$$

$$T_m = t_m + 460$$

$$M_s = M_d \left( 1 - B_{ws(\text{est})} \right) + 18 B_{ws(\text{est})}$$

06-03

### Methods for Calculating $D_n$ (est) and K

06-04

## Isokinetic Sampling Rate Derivation

### 1. Simplified Isokinetic Rate Equation

$$\Delta H = K \Delta p \quad (5-1)$$

Where:  $D_n$  = the nozzle diameter

### 2. Nozzle Tip Volumetric Flow Rate Under Isokinetic Conditions

$$Q_n = A_n v_n = A_n v_s = \frac{\pi D_n^2}{4} v_s \quad (5-2)$$

Where:  $D_n$  = the nozzle diameter

### 3. Orifice Meter Equation

$$Q_m = K_m \sqrt{\frac{T_m \Delta H}{P_m M_m}} \quad (5-3)$$

### 4. T and P Correction for Dry Gas Stream

$$Q_n = \frac{P_m T_s}{P_s T_m} Q_m \quad (5-4)$$

### 5. Moisture Correction

However, for a wet gas stream

$$n_s (1 - B_{ws}) = n_m (1 - B_{wm}) \quad (5-5)$$

Where:  $n_s$  = the number of moles of gas entering the nozzle  
 $n_m$  = the number of moles of gas leaving the meter

Assume:  $B_{wm} = 0$

$$\text{So: } n_s = \frac{n_m}{(1 - B_{ws})}$$

## Notes

## 12. Simplifying

$$\text{Let } \Delta H_{\text{e}} = \frac{0.9244}{(K_m)^2} \quad (5-12)$$

$$\text{and } K_p = 85.49$$

$\Delta H_{\text{e}}$  is defined as the orifice pressure differential that gives 0.75 cfm of air at 68° F and 29.92 in. Hg.

$$\Delta H = \frac{Q_m^2 P_m M_m}{K_m^2 T_m} \quad (5-12)$$

$$\Delta H_{\text{e}} = \frac{(0.75 \text{ cfm})^2 (29.92 \text{ in. Hg}) (29.0)}{(460 + 68) K_m^2}$$

$$\Delta H_{\text{e}} = \frac{0.9244}{K_m^2}$$

## 13. Isokinetic Rate Equation - Working Form

$$\Delta H = \left\{ 846.72 D_n^4 \Delta H_{\text{e}} C_p^2 (1 - B_{ws})^2 \frac{M_d T_m P_s}{M_s T_s P_m} \right\} \Delta p \quad (5-13)$$

## 13a. Moisture Relationships

$$[M_s = M_d (1 - B_{ws}) + 18 B_{ws}] \quad (5-13a)$$

## 14. Nozzle Diameter Selection Equation

$$D_n = \sqrt{\left( \frac{0.0358 Q_m P_m}{T_m C_p (1 - B_{ws})} \right) \sqrt{\frac{T_s M_s}{P_s \Delta p_{\text{est}}}}} \quad (5-14)$$

Where:  $\Delta p_{\text{est}}$  (which is usually the same as  $\Delta p_{\text{avg}}$ ) is an estimate of the average pitot tube pressure drop readings that one would observe at the measurement points.

The derivation of this equation is left as an exercise to the student.

*Note:* Average  $\Delta p$  obtained from pitot tube traverse.

## Isokinetic Rate Equation Lecture Problem

Given the following information, use Equation 5-14 to determine the appropriate nozzle to be used in the test. Then use Equation 5-13 to determine the K value for setting the isokinetic sampling rate. Note that you will also have to use Equation 5-13a to calculate  $M_s$ .

$$Q_m = 0.75 \text{ cfm}$$

$$\Delta H_{@} = 1.85$$

$$\text{Pitot tube } C_p = 0.85$$

$$t_m = 80^\circ \text{ F}$$

$$P_m = 30.0 \text{ in. Hg}$$

$$P_s = 29.6 \text{ in. Hg}$$

$$B_{wm} = 0$$

$$B_{ws} = 0.12$$

$$t_s = 280^\circ \text{ F}$$

$$M_d = 29 \text{ lb/lb-mole}$$

$$\Delta p_{\text{est}} = 0.80 \text{ in. H}_2\text{O}$$

Assume that in your toolbox, you have nozzles with the following diameters: 0.125 in., 0.25 in., 0.375 in., and 0.50 in.

Calculations:

## Isokinetic Rate Equation Lecture Problem

Given the following information, use Equation 5-14 to determine the appropriate nozzle to be used in the test. Then use Equation 5-13 to determine the K value for setting the isokinetic sampling rate. Note that you will also have to use Equation 5-13a to calculate  $M_s$ .

$$Q_m = 0.75 \text{ cfm}$$

$$\Delta H_{\text{e}} = 1.85$$

$$\text{Pitot tube } C_p = 0.85$$

$$t_m = 80^\circ \text{ F}$$

$$P_m = 30.0 \text{ in. Hg}$$

$$P_s = 29.6 \text{ in. Hg}$$

$$B_{wm} = 0$$

$$B_{ws} = 0.12$$

$$t_s = 280^\circ \text{ F}$$

$$M_d = 29 \text{ lb/lb-mole}$$

$$\Delta p_{\text{est}} = 0.80 \text{ in. H}_2\text{O}$$

Assume that in your toolbox, you have nozzles with the following diameters: 0.125 in., 0.25 in., 0.375 in., and 0.50 in.

Calculations:

## 12. Simplifying

$$\text{Let } \Delta H_{\text{e}} = \frac{0.9244}{(K_m)^2} \quad (5-12)$$

and  $K_p = 85.49$

$\Delta H_{\text{e}}$  is defined as the orifice pressure differential that gives 0.75 cfm of air at 68° F and 29.92 in. Hg.

$$\Delta H = \frac{Q_m^2 P_m M_m}{K_m^2 T_m} \quad (5-12)$$

$$\Delta H_{\text{e}} = \frac{(0.75 \text{ cfm})^2 (29.92 \text{ in. Hg}) (29.0)}{(460 + 68) K_m^2}$$

$$\Delta H_{\text{e}} = \frac{0.9244}{K_m^2}$$

## 13. Isokinetic Rate Equation - Working Form

$$\Delta H = \left\{ 846.72 D_n^4 \Delta H_{\text{e}} C_p^2 (1 - B_{ws})^2 \frac{M_d T_m P_s}{M_s T_s P_{rn}} \right\} \Delta p \quad (5-13)$$

## 13a. Moisture Relationships

$$[M_s = M_d (1 - B_{ws}) + 18 B_{ws}] \quad (5-13a)$$

## 14. Nozzle Diameter Selection Equation

$$D_n = \sqrt{\left( \frac{0.0358 Q_m P_m}{T_m C_p (1 - B_{ws})} \right) \sqrt{\frac{T_s M_s}{P_s \Delta p_{\text{est}}}}} \quad (5-14)$$

Where:  $\Delta p_{\text{est}}$  (which is usually the same as  $\Delta p_{\text{avg}}$ ) is an estimate of the average pitot tube pressure drop readings that one would observe at the measurement points.

The derivation of this equation is left as an exercise to the student.

*Note:* Average  $\Delta p$  obtained from pitot tube traverse.



## Notes

## Isokinetic Sampling Rate Derivation

### 1. Simplified Isokinetic Rate Equation

$$\Delta H = K\Delta p \quad (5-1)$$

Where:  $D_n$  = the nozzle diameter

### 2. Nozzle Tip Volumetric Flow Rate Under Isokinetic Conditions

$$Q_n = A_n v_n = A_n v_s = \frac{\pi D_n^2}{4} v_s \quad (5-2)$$

Where:  $D_n$  = the nozzle diameter

### 3. Orifice Meter Equation

$$Q_m = K_m \sqrt{\frac{T_m \Delta H}{P_m M_m}} \quad (5-3)$$

### 4. T and P Correction for Dry Gas Stream

$$Q_n = \frac{P_m T_s}{P_s T_m} Q_m \quad (5-4)$$

### 5. Moisture Correction

However, for a wet gas stream

$$n_s (1 - B_{ws}) = n_m (1 - B_{wm}) \quad (5-5)$$

Where:  $n_s$  = the number of moles of gas entering the nozzle  
 $n_m$  = the number of moles of gas leaving the meter

Assume:  $B_{wm} = 0$

$$\text{So: } n_s = \frac{n_m}{(1 - B_{ws})}$$

## Lesson 6

### Course 450

Use of Computers and Programmable  
Calculators for Isokinetic Sampling

06-01

### The Basic Calculations

$$D_{n(\text{est})} = \frac{0.0358 Q_m P_m}{\sqrt{T_m C_p (1 - B_{ws(\text{est})})}} \sqrt{\frac{T_s M_s}{P_s \Delta p_{\text{est}}}}$$

$$\Delta H = \left\{ 846.72 D_n^4 \Delta H_e C_p^2 (1 - B_{ws})^2 \frac{M_d T_m P_s}{M_s T_s P_m} \right\}$$

06-02

### The Basic Calculations

$$\Delta H = K \Delta p$$

$$T_s = t_s + 460$$

$$T_m = t_m + 460$$

$$M_s = M_d \left( 1 - B_{ws(\text{est})} \right) + 18 B_{ws(\text{est})}$$

06-03

### Methods for Calculating $D_n$ (est) and K

06-04

Therefore: mass/minute =  $4 \times 6 + 2 \times 0.03 = 24.1$  m.u./minute

$$c_n = \frac{24.1 \text{ m.u./min}}{1/2 \text{ ft}^3\text{min}} = 48.2 \frac{\text{m.u.}}{\text{ft}^3}$$

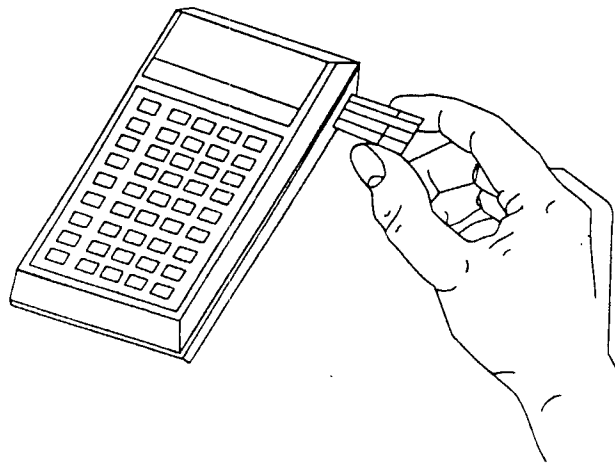

Figure 6-3. Calculator with removable memory chips

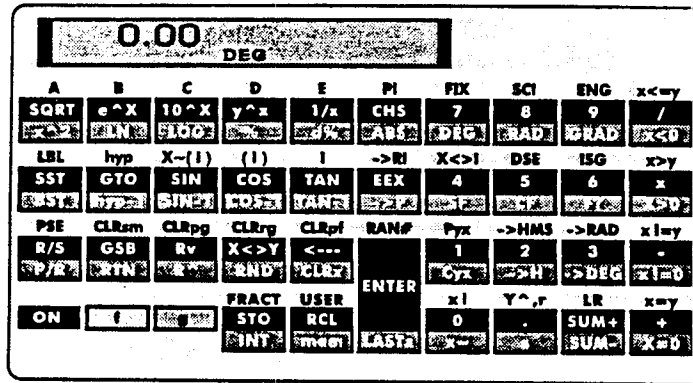

Figure 6-4. Scientific calculator

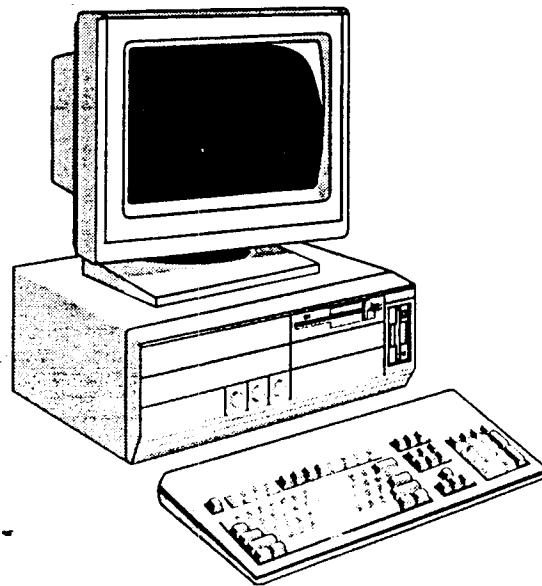

Figure 6-5. Computer

## Isokinetic Sampling

Isokinetic sampling conditions exist when the velocity of the gas entering the probe nozzle tip ( $v_n$ ) is exactly equal to the velocity of the approaching stack gases ( $v_s$ ), that is  $v_n = v_s$ . The percent isokinetic is defined as:

$$\% \text{ isokinetic} = \frac{v_n}{v_s} \times 100$$

and is equal to 100% only when  $v_n = v_s$ . When  $v_n \neq v_s$  (anisokinetic conditions), sample concentrations can be biased due to the inertial effects of particles.

If the gas-flow streamlines are disturbed as in anisokinetic conditions:

1. Large particles tend to move in the same initial direction.
2. Small particles tend to follow the streamlines.
3. Intermediate particles are somewhat deflected.

As an example, assume that we have a large particle of 6 mass units (m.u.) and a small particle of 0.03 mass units. Consider the following situations:

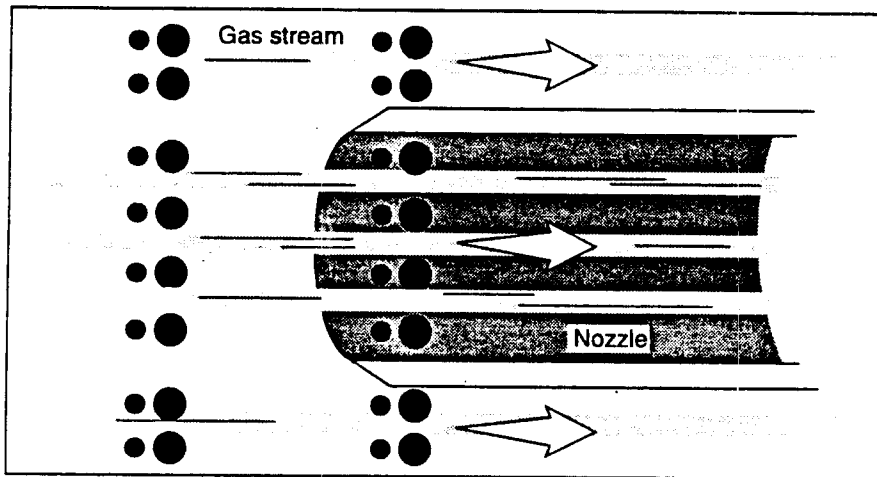

Figure 4-1. 100% isokinetic

Assume:  $v_n = v_s$   
 $Q_n = 1 \text{ cfm}$   
 4 large and 4 small particles are collected/minute

Therefore: mass/minute =  $4 \times 6 + 4 \times 0.03 = 24.1 \text{ m.u./minute}$

$$c_n = \frac{24.1 \text{ m.u./min}}{1 \text{ ft}^3 \text{ min}} = 24.1 \frac{\text{m.u.}}{\text{ft}^3}$$

### Other Options

- Methods 1, 2, 3, 4 calculations
- Report programs - print-out of results
- Field cross-check programs
- Fancy graphics - displays

06-08

### Published Programs

#### Calculator

- TI-59     EPA 450/2-83-006
- HP-41     EPA 340/1-85-018
- HP-65     EPA 600/8-76-002

#### Programs in Basic

- See EMTIC bulletin board

06-09

# **Lesson 7**

## **Methods 1-4**

### **Lesson Goal**

The goal of this lesson is to describe how Methods 1-4 are performed and the calculations used in each method.

### **Lesson Objectives**

Upon completion of this lesson, you should be able to:

1. Discuss why it is necessary to perform traverses of a stack cross-section when source sampling.
2. Distinguish between "upstream" and "downstream" as used in reference method terminology.
3. Determine the number of sampling points and their locations, for both circular and rectangular ducts.
4. Explain what a Type S pitot tube is and how it works.
5. Recite the pitot tube equation from memory.
6. Identify at least three design criteria that a Type S pitot tube must meet if its  $C_p$  value can be assumed to be 0.84.
7. Describe how a pitot tube can be calibrated in a calibration duct.
8. Describe how a velocity traverse is performed.
9. Properly average the results of a pitot tube traverse.
10. Describe three methods of determining the stack static pressure,  $p_s$ .
11. Describe three sampling procedures used in Method 3.
12. Describe what an Orsat analyzer is and how it is used to determine the dry molecular weight of a flue gas.
13. Describe Method 3A and list three performance test procedures that must be conducted before the method may be used.
14. Use the fuel factor for cross-checking Method 3 or Method 3A data.



15. Recognize the equation used for calculating percent excess air, %EA.
16. Describe three approximation methods that may be used for estimating flue gas moisture content.
17. Describe how the wet bulb-dry bulb technique is performed.
18. Discuss how Method 4 is conducted with Method 5.

**Lesson 7**

**Course 450**

Methods 1-4

07-01

**Method 1**

Sample and Velocity  
Traverse Points

07-02

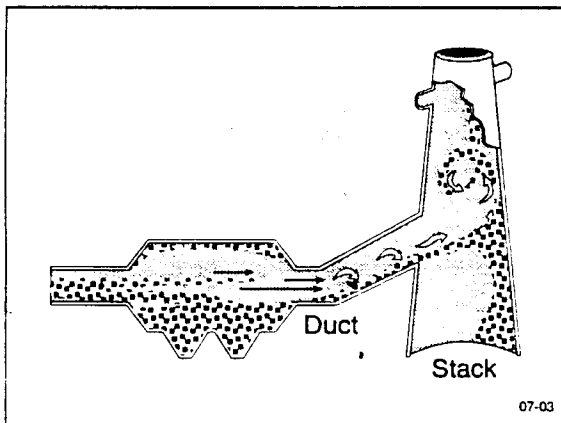

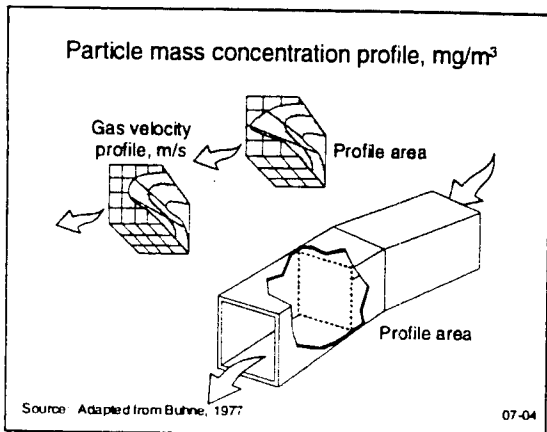

**Determining the Number of Traverse Points**

07-05

**Equivalent Diameters**

$$D_e = \frac{2 LW}{(L + W)}$$

07-06

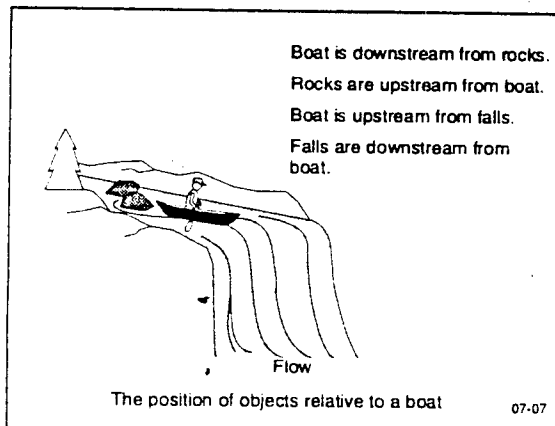

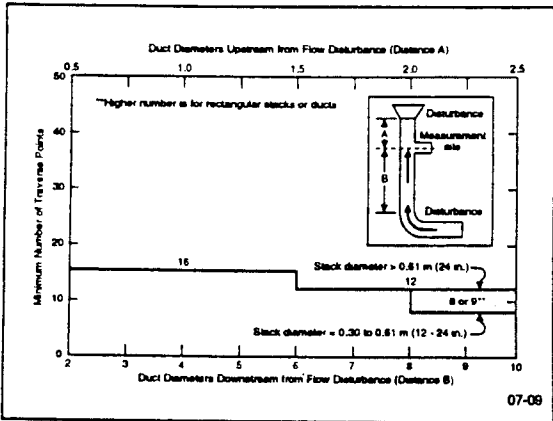
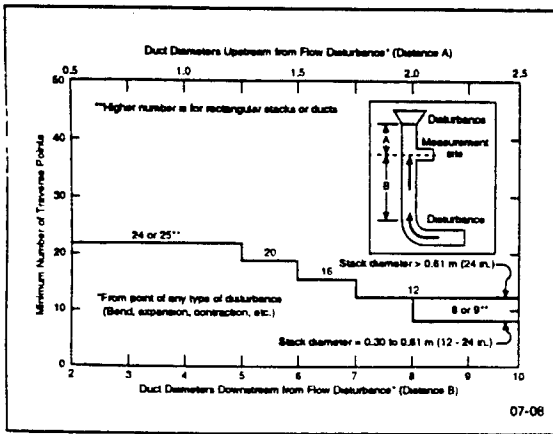

### Cross-Sectional Layout and Location of Traverse Points

07-10

Table 1-1. Cross-Section Layout for Rectangular Stacks

Number of traverse points	Matrix layout
9	3x3
12	4x3
16	4x4
20	5x4
25	5x5
30	6x5
36	6x6
42	7x6
49	7x7

07-11

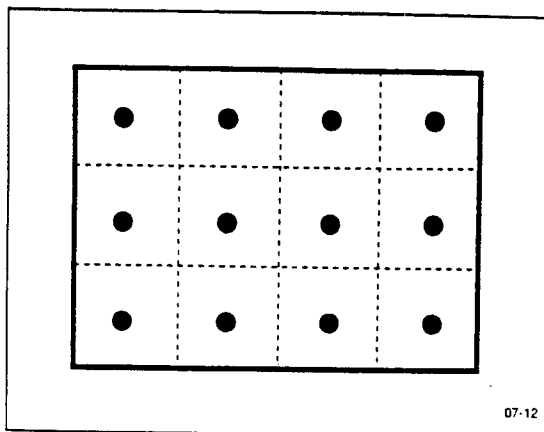

07-12

**Table 1-2. Location of Traverse Points in Circular Stacks**  
*(Percent of stack diameter from both wall to traverse point)*

Traverse point on a diameter	Number of traverse points on a diameter											
	2	4	6	8	10	12	14	16	18	20	22	24
1	14.6	8.7	4.4	3.2	2.6	2.1	1.8	1.6	1.4	1.3	1.1	1.1
2	86.4	25.0	14.6	10.3	8.2	6.7	5.7	4.9	4.4	3.9	3.6	3.2
3	75.0	28.6	19.4	14.6	11.8	9.9	8.6	7.4	6.6	5.7	5.2	4.6
4	61.3	30.4	22.3	17.7	14.8	12.5	10.9	9.7	8.7	7.8	7.2	6.5
5	46.4	31.7	24.2	20.2	17.1	14.9	13.0	11.6	10.4	9.4	8.7	8.0
6	30.6	30.6	26.8	24.8	22.0	19.8	18.5	16.8	15.2	14.0	13.2	12.2
7	14.6	27.4	26.8	24.8	22.0	19.8	18.5	16.8	15.2	14.0	13.2	12.2
8	86.4	30.6	26.8	24.8	22.0	19.8	18.5	16.8	15.2	14.0	13.2	12.2
9	75.0	30.6	26.8	24.8	22.0	19.8	18.5	16.8	15.2	14.0	13.2	12.2
10	61.3	30.6	26.8	24.8	22.0	19.8	18.5	16.8	15.2	14.0	13.2	12.2
11	46.4	30.6	26.8	24.8	22.0	19.8	18.5	16.8	15.2	14.0	13.2	12.2
12	30.6	30.6	26.8	24.8	22.0	19.8	18.5	16.8	15.2	14.0	13.2	12.2
13	14.6	27.4	26.8	24.8	22.0	19.8	18.5	16.8	15.2	14.0	13.2	12.2
14	86.4	27.4	26.8	24.8	22.0	19.8	18.5	16.8	15.2	14.0	13.2	12.2
15	75.0	27.4	26.8	24.8	22.0	19.8	18.5	16.8	15.2	14.0	13.2	12.2
16	61.3	27.4	26.8	24.8	22.0	19.8	18.5	16.8	15.2	14.0	13.2	12.2
17	46.4	27.4	26.8	24.8	22.0	19.8	18.5	16.8	15.2	14.0	13.2	12.2
18	30.6	27.4	26.8	24.8	22.0	19.8	18.5	16.8	15.2	14.0	13.2	12.2
19	14.6	27.4	26.8	24.8	22.0	19.8	18.5	16.8	15.2	14.0	13.2	12.2
20	86.4	27.4	26.8	24.8	22.0	19.8	18.5	16.8	15.2	14.0	13.2	12.2
21	75.0	27.4	26.8	24.8	22.0	19.8	18.5	16.8	15.2	14.0	13.2	12.2
22	61.3	27.4	26.8	24.8	22.0	19.8	18.5	16.8	15.2	14.0	13.2	12.2
23	46.4	27.4	26.8	24.8	22.0	19.8	18.5	16.8	15.2	14.0	13.2	12.2
24	30.6	27.4	26.8	24.8	22.0	19.8	18.5	16.8	15.2	14.0	13.2	12.2

07-13

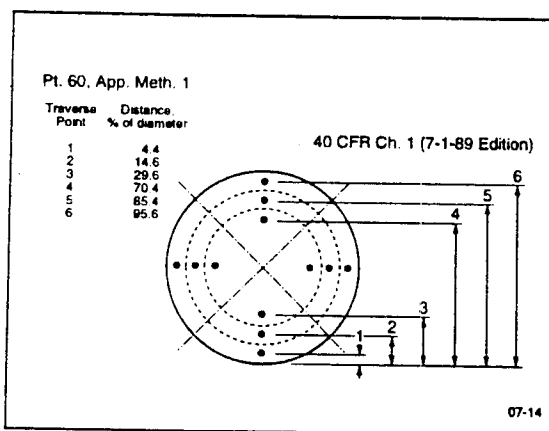

07-14

**Method 2**

Determination of  
Stack Gas Velocity  
and  
Volumetric Flow Rate  
(Type S Pitot Tube)

07-15

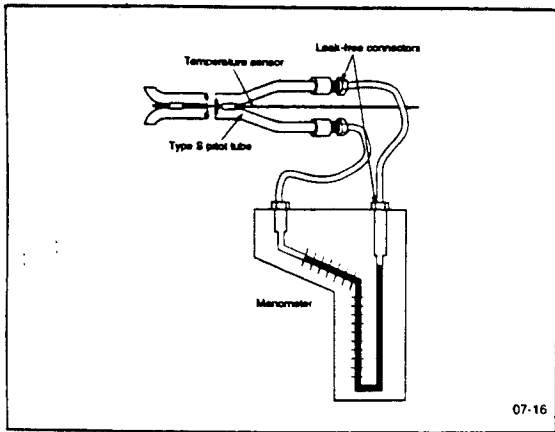

$$v_s = K_p C_p \sqrt{\frac{T_s \Delta p}{M_s P_s}}$$

07-17

### Pitot Tube Calibration

Dimensional specification  
and/or

Calibrate in wind tunnel against  
standard pitot tube, preferably with  
National Bureau of Standards (NBS)  
traceable coefficient

07-18

### Type S Pitot Tube

Design criteria for assigning

$$C_p = 0.84$$

07-19

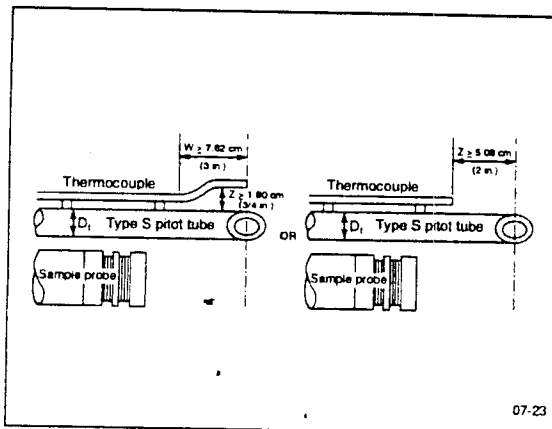
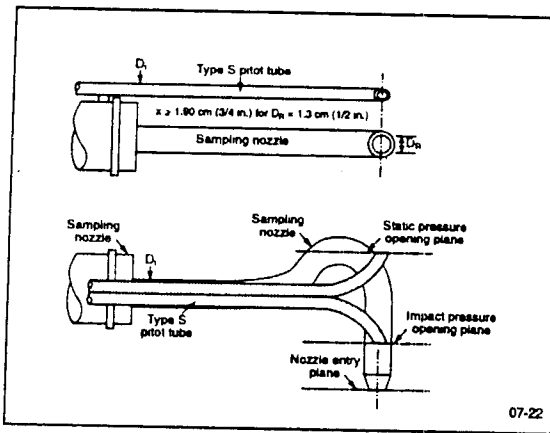
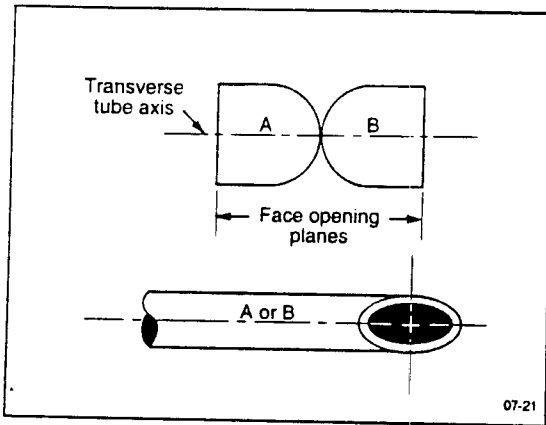
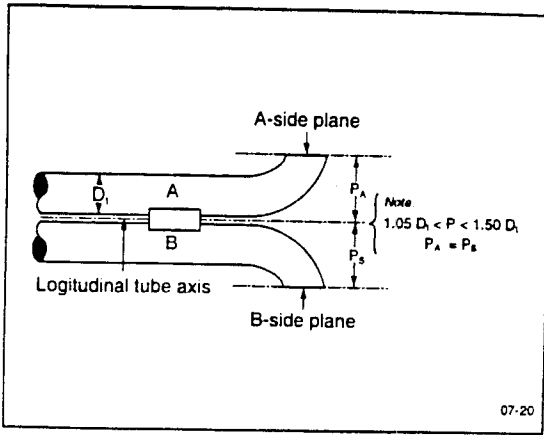

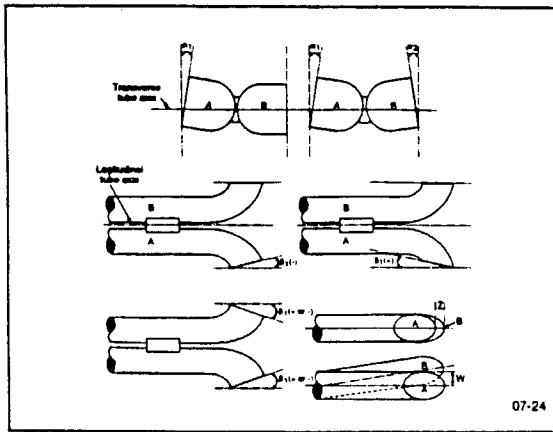

### Type S Pitot Tube Calibration Using a Standard Pitot Tube and Wind Tunnel

07-25

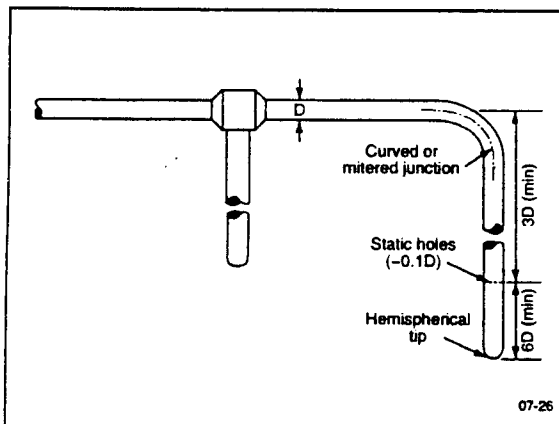

### Calibration Duct

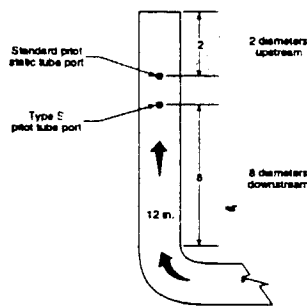





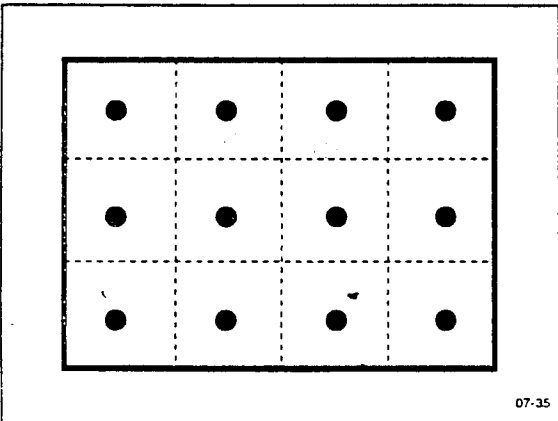
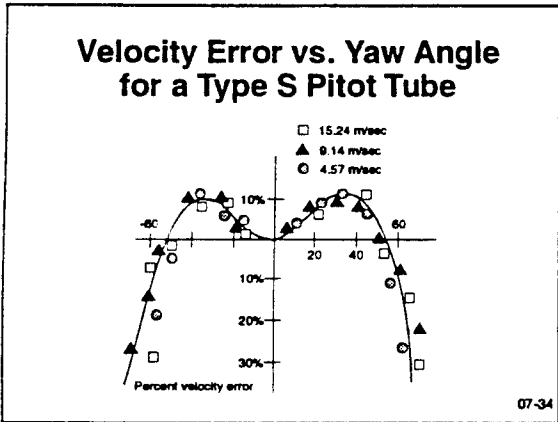
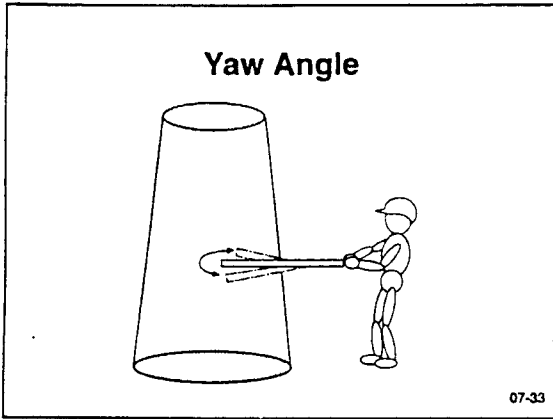
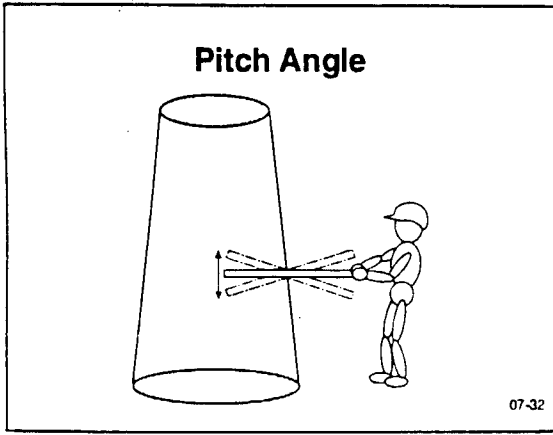

### Average Velocity over the Cross-Section

$$\bar{v}_s = K_p C_p (\sqrt{\Delta p})_{avg} \sqrt{\frac{T_{s(avg)}}{M_s P_s}}$$

07-36

### Average Stack Gas Dry Volumetric Flow Rate

$$Q_{std} = 3600 (1 - B_{ws(avg)}) v_{s(avg)} A \frac{T_{std} P_s}{T_{s(avg)} P_{std}}$$

07-37

### Static Pressure Measurement ( $P_g$ )

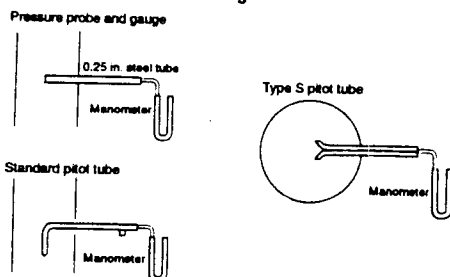

07-38

$$P_s = P_b + \frac{P_g}{13.6}$$

07-39

## Barometric Pressure

Barometric pressure during testing is obtained by:

### Instrument

- Mercury, aneroid or other barometer (with required sensitivity)

### Other

- Obtain barometric pressure from nearby National Weather Service station (station pressure) and adjust for elevation differences between sampling site and weather station.

*Note:* The station pressure must be used not the pressure corrected to sea level.

07-40

## Pressure Probe and Gauge

Static pressure measurement must be accurate to within 1 in. Hg (13.6 in. H<sub>2</sub>O).

Pressure sensors typically used to measure static pressure during testing include:

- A piezometer tube and mercury or water-filled U-tube manometer
- The static tap of a pitot tube
- One leg of the Type S pitot tube

07-41

## Applicability

Method 2 is applicable only at sites that:

- Meet the criteria of Method 1
- Do not contain cyclonic or non-parallel flow

07-42

## Alternatives When Unacceptable Conditions Exist

(Subject to approval of the Administrator)

- Install straightening vanes.
- Calculate total volumetric flow rate stoichiometrically.
- Move to a measurement site at which flow is acceptable.
- Use procedures as described in Method 2 for cyclonic flow.

07-43

### Method 3

#### Gas Analysis for Determination of Dry Molecular Weight

07-44

#### Principle

A gas sample is collected by one of the following methods:

- Single-point grab sampling
- Single-point integrated sampling
- Multi-point integrated sampling

07-45

#### Principle

The sample is analyzed for the following components:

- Carbon dioxide (CO<sub>2</sub>)
- Oxygen (O<sub>2</sub>)
- Carbon monoxide (CO)(if necessary)

07-46

#### Applicability

For determining dry molecular weight and excess air correction factor from fossil-fuel combustion sources

07-47

### Sampling Procedures

- Single-point grab
- Single-point integrated
- Multi-point integrated

### Analytical Procedures

- Orsat (Method 3)
- Automated (Method 3A)

07-48

### Sampling Methods

07-49

### Grab-Sampling Train

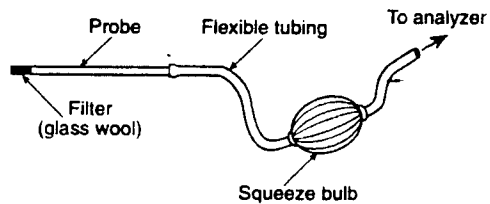

07-50

### Single-Point Grab Sampling

1. Sample point should be at the centroid of the cross-section or at a point at least 1 m from the wall of a large stack.
2. Place probe securely in stack and seal sampling port to prevent dilution of stack gas.
3. Purge sample line and attach to analyzer.
4. Aspirate sample into analyzer.

07-51

### Integrated Gas Sampling Train

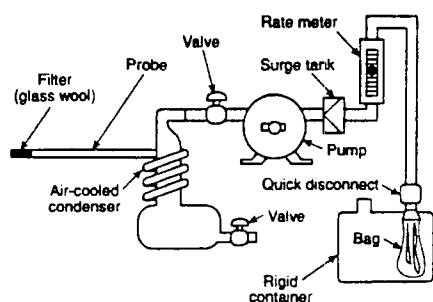

07-52

### Single-Point Integrated Sampling

1. Sample point and probe placement is same as for single-point grab sampling.
2. Leak-check the flexible bag.
3. Leak-check the sampling train.
4. Connect probe to train and purge the system.
5. Connect evacuated flexible bag and begin sampling.
6. Sample at constant rate; collect 30 to 90 L of gas simultaneous with pollutant emission test.

07-53

### Multi-Point Integrated Sampling

1. This procedure uses same sampling train and equipment preparation as the single-point integrated sampling method.
2. Locate sampling points according to Method 1.
3. Sample each point at the same rate and for the same time increment.
4. Collect 30 to 90 L of gas simultaneous with pollutant emission test.

07-54

### Multi-Point Integrated Sampling

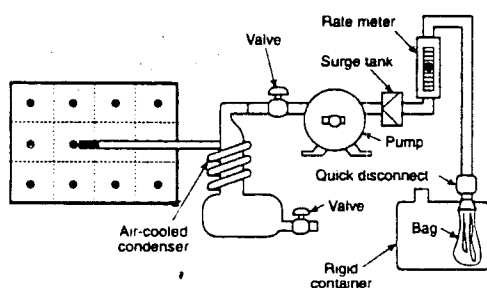

07-55

## Analysis

07-56

## Orsat Analyzer

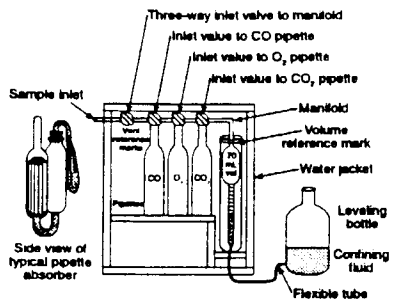

07-57

## Orsat Analyzer Reagents

### Gas Confining Solution

A solution containing sodium sulfate, sulfuric acid and methyl orange

### Carbon Dioxide Absorbent

A solution of potassium or sodium hydroxide

### Oxygen Absorbent

A solution of alkaline pyrogallic acid or chromous chloride

### Carbon Monoxide Absorbent

A solution of cuprous chloride or a sulfate solution

07-58

## Fyrite Analyzer

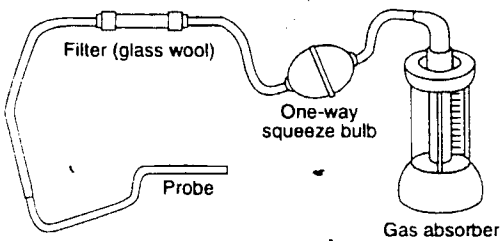

07-59

### Dry Molecular Weight Equation

$$M_d = 0.44(\%CO_2) + 0.32(\%O_2) + 0.28(\%N_2 + \%CO)$$

Where:  $M_d$  = dry molecular weight  
 $\%CO_2$  = percent  $CO_2$  by volume (dry basis)  
 $\%O_2$  = percent  $O_2$  by volume (dry basis)  
 $\%CO$  = percent  $CO$  by volume (dry basis)  
 $\%N_2$  = percent  $N_2$  by volume (dry basis)  
 0.44 = molecular weight of  $CO_2$  divided by 100  
 0.32 = molecular weight of  $O_2$  divided by 100  
 0.28 = molecular weight of  $N_2$  divided by 100  
 0.28 = molecular weight of  $CO$  divided by 100

07-60

### Method 3A

Determination of  $O_2$  and  $CO_2$   
 Concentrations in Emissions from  
 Stationary Sources

(Instrumental Analyzer Procedure)

07-61

### Applicability

For the determination of  $O_2$  and  
 $CO_2$  only when specified within the  
 regulations

07-62

### Principle

A sample is continuously extracted from the effluent stream. A portion of the sample stream is sent to an instrumental analyzer(s) for the determination of  $O_2$  and  $CO_2$  concentrations.

07-63



## Analyzer Operating Principles

### CO<sub>2</sub> Analyzers

- Nondispersive infra-red
- Polarography

### O<sub>2</sub> Analyzers

- Paramagnetism
- Polarography
- Electrocatalsis

07-64

## Measurement System Schematic

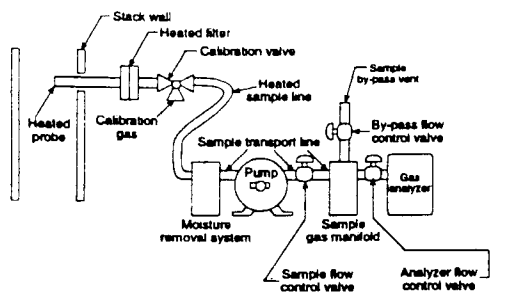

07-65

## Performance Test Procedures

- Calibration error check
- Sampling system bias check
- Interference response check

07-66

## Performance Test Criteria

### Calibration Error -

- $< \pm 2\%$  of span for zero, mid, high range gases
- (0) (40-60) (80-100) % of span

### Sampling System

### Bias Check -

- $< \pm 5\%$  of span for zero and high range gases

07-67

## Performance Test Criteria

### Interference Response

<  $\pm 2\%$  of span

For CO @ 500 ppm

SO<sub>2</sub> @ 200 ppm

CO<sub>2</sub> @ 10%

O<sub>2</sub> @ 20.9%

07-68

## Method 3A

### Test Procedure

- Sample collection
- Zero and calibration drift test

07-69

## Method 3B

Gas Analysis for the Determination  
of Emission Rate Correction Factor or  
Excess Air Using the Orsat Analyzer

07-70

## Applicability

For determining CO<sub>2</sub>, O<sub>2</sub>, and CO  
from a gas stream from a fossil-fuel  
combustion process

07-71

### The Fuel Factor

$$F_o = \frac{20.9 - \%O_2}{\%CO_2}$$

07-72

F<sub>o</sub> Acceptable Ranges

Fuel Type	F <sub>o</sub> range
<b>Coal</b>	
Anthracite and lignite .....	1.016 - 1.130
Bituminous .....	1.083 - 1.230
<b>Oil</b>	
Distillate .....	1.260 - 1.413
Residual .....	1.210 - 1.370
<b>Gas</b>	
Natural .....	1.800 - 1.836
Propane .....	1.434 - 1.568
Butane .....	1.405 - 1.563
Wood .....	1.000 - 1.120
Wood bark .....	1.003 - 1.130

07-73

### Percent Excess Air Equation

$$\%EA = \left[ \frac{\%O_2 - 0.5\%CO}{0.264\%N_2 - (\%O_2 - 0.5\%CO)} \right] 100$$

Where: %EA = percent excessive air  
 %O<sub>2</sub> = percent O<sub>2</sub> by volume (dry basis)  
 %CO = percent CO by volume (dry basis)  
 %N<sub>2</sub> = percent N<sub>2</sub> by volume (dry basis)  
 0.264 = ratio of O<sub>2</sub> to N<sub>2</sub> in air, V/V

07-74

### Method 4

Determination of  
 Moisture Content in Stack Gases

07-75

### Principle

A sample is extracted at a constant rate. Moisture is removed and determined volumetrically or gravimetrically.

07-76

### Applicability

For determining moisture content of stack gas.

07-77

### Approximation Methods

Used to estimate percent moisture to aid in setting isokinetic sampling rate

Wet bulb-dry bulb

Partial pressure technique  
(at saturation)

Approximation sampling method

07-78

### Wet Bulb - Dry Bulb Method

1. Measure the wet bulb temperature.
2. Measure the dry bulb temperature.
3. Estimate moisture content using psychrometric chart

or

Calculate moisture content.

07-79

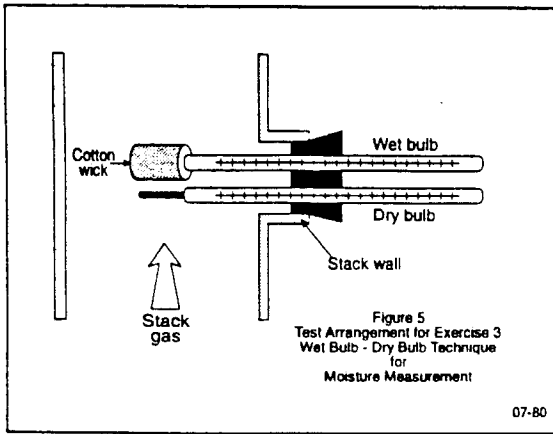

07-80

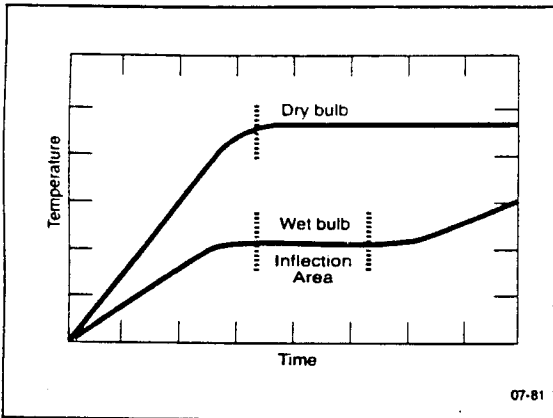

07-81

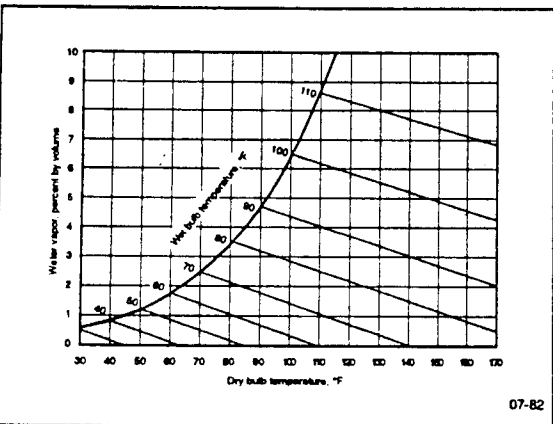

07-82

### Moisture Equation (Wet Bulb - Dry Bulb)

$$B_{ws} = \frac{v.p.}{P_s}$$

Where:  $v.p. = s.v.p. - (3.67 \times 10^{-4})(P_s)(t_d - t_w) \left(1 + \frac{t_w - 32}{1571}\right)$

- s.v.p. = saturated water vapor pressure at the wet bulb temperature
- P = absolute pressure in the stack
- $t_d$  = dry bulb temperature
- $t_w$  = wet bulb temperature
- v.p. = water vapor pressure

07-83

### Partial Pressure Method

- Assume saturation.
- Attach temperature sensor to reference method probe.
- Measure stack gas temperature at each traverse point.
- Calculate the average stack gas temperature.
- Determine moisture fraction using saturation vapor pressure table.

07-84

### Moisture Equation - Partial Pressure

$$B_{ws} = \frac{s.v.p.}{P_s}$$

Where:  $B_{ws}$  = proportion (by volume) of water vapor in a gas mixture  
 s.v.p. = saturated vapor pressure of water at average stack temperature  
 $P_s$  = absolute pressure of the stack

07-85

### Moisture Sampling Train - Approximation Method

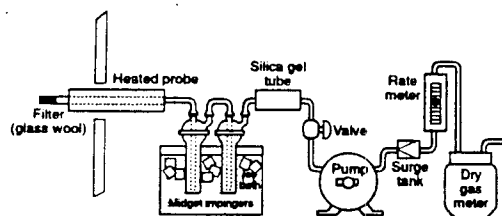

07-86

### Procedure

1. Place 5.0 ml of distilled water in each impinger.
2. Assemble and leak-check sampling train.
3. Sample at a constant rate of 0.07 cfm until a sample volume of 1.1 ft<sup>3</sup> is obtained.
4. Combine contents of impingers and measure volume to nearest 0.5 mL.

07-87

## Reference Method

- Used for accurate determination of moisture content
- Usually conducted simultaneously with a pollutant measurement run
- Results used to calculate the percent isokinetic and pollutant emission rate

07-86

## Moisture Sampling Train (Reference Method)

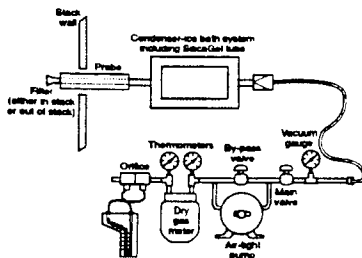

07-89

## Procedure

1. Determine traverse points using Method 1.
2. Select sampling time such that minimum gas volume of 21 scf will be collected at rate no greater than 0.75 cfm.
3. Leak-check sampling train (optional).
4. Maintain sampling rate within 10% of constant rate.
5. After sampling, leak-check sampling train (mandatory).
6. Verify the constant sampling rate.

07-90

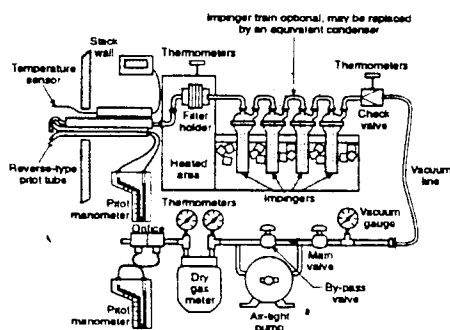

07-91

### Volume of Water Vapor Condensed

$$V_{wc(std)} = \frac{(V_f - V_i) \rho_w RT_{std}}{P_{std} M_w}$$

$$= K_1 (V_f - V_i)$$

Where:  $K_1 = 0.001333 \text{ m}^3/\text{mL}$  for metric units  
 $= 0.04707 \text{ ft}^3/\text{mL}$  for English units

07-92

### Volume of Water Vapor Collected in Silica Gel

$$V_{wsg(std)} = \frac{(W_f - W_i) RT_{std}}{P_{std} M_w}$$

$$= K_2 (W_f - W_i)$$

Where:  $K_2 = 0.001335 \text{ m}^3/\text{g}$  for metric units  
 $= 0.04715 \text{ ft}^3/\text{g}$  for English units

07-93

### Sample Gas Volume

$$V_{m(std)} = V_m Y \frac{(P_m)(T_{std})}{(P_{std})(T_m)}$$

$$= K_3 Y \frac{V_m P_m}{T_m}$$

Where:  $K_3 = 0.3858 \text{ K/mmHg}$  for metric units  
 $= 17.64 \text{ R/in. Hg}$  for English units

07-94

### Moisture Content

$$B_{ws} = \frac{V_{wc(std)} + V_{wsg(std)}}{V_{wc(std)} + V_{wsg(std)} + V_{m(std)}}$$

07-95



## ***Second Day Laboratory Exercise***

In this laboratory, you and your assigned group will be performing a pitot tube traverse. The directions are given on page A-1 of Appendix A (Laboratory Exercises).

Take notes here for background information and any special instructions given by the Course Director or Laboratory Instructors.

## Notes

## Notes

---

# **Homework Review 2**

## **Question-and-Answer Session**

### **Session Goal**

The goal of this session is to review homework problems assigned on Day 1 and to provide you with the opportunity to discuss any questions or issues presented in the previous day's sessions.

### **Session Objectives**

After completing this review, you will be able to do the following:

1. Meet the goals and objectives of yesterday's sessions.
2. Perform calculations similar to those provided in the Homework Exercise.

## Notes

# Notes

## Notes

# **Lesson 8**

## ***Calculation and Interpretation of Percent Isokinetic***

### ***Lesson Goal***

The goal of this lesson is to present the concept of percent isokinetic (%I), derive the expression given for %I and to discuss a method used for evaluating the adequacy of source tests that are not 100% isokinetic.

### ***Lesson Objectives***

Upon completion of this lesson, you should be able to:

1. Discuss how the percent isokinetic expression is derived.
2. Explain the relative importance of the variables in the percent isokinetic expression and point out which ones should be checked closely on the source test report.
3. Illustrate the effect of under-isokinetic sampling on the measured pollutant mass rate (pmr), relative to the true pmr.
4. Illustrate the effect of over-isokinetic sampling on the measured pmr, relative to the true pmr.
5. Evaluate whether a source test should be rejected or accepted, based upon the value of the percent isokinetic and whether the emission rate value is either above or below the standard.



## Percent Isokinetic Derivation

### 1. Percent Isokinetic Variation

$$\%I = \frac{v_n}{v_s} \times 100 \quad (8-1)$$

### 2.

$$v_n = \frac{Q_n}{A_n} \quad (8-2)$$

### 3. $Q_n$ from Collected Data

$$Q_n = \frac{V_{sw} + V_{\text{meter corr}}}{\theta}$$

Where:  $\theta$  = sampling time period

### 4. Correction of Metered Volume to Volume at Stack Conditions

$$V_{\text{orifice corr}} = \left( \frac{T_s \left( P_b + \frac{\Delta H}{13.6} \right)}{P_s T_m} \right) V_m \quad (8-4)$$

### 5. Correction for Water Collected in Impinger

$$V_{lc} \rho_{H_2O} = m_{H_2O} \quad (8-5)$$

$$P_s V_{sw} = \frac{m}{M} RT_s$$

and 
$$V_{sw} = m_{H_2O} \frac{RT_s}{M_{H_2O} P_s}$$

$$V_{sw} = V_{lc} \rho_{H_2O} \frac{RT_s}{M_{H_2O} P_s} = \text{The volume of water vapor at stack conditions}$$

6. Substituting into  $Q_n$

$$Q_n = \frac{\frac{T_s}{P_s} \left[ V_{lc} K_3 + \frac{V_m}{T_m} \left( P_b + \frac{\Delta H}{13.6} \right) \right]}{\theta} \quad (8-6)$$

$$\text{Where: } K_3 = \frac{\rho_{H_2O} R}{M_{H_2O}} = 0.00267 \frac{\text{in. Hg ft}^3}{\text{mL R}}$$

7. But remember that:

$$\%I = \frac{v_n}{v_s} 100 = \frac{Q_n}{v_s A_n} 100 \quad (8-7)$$

8. Substitute Equation 8-6 into Equation 8-7 to obtain

$$\%I = \frac{100 T_s \left[ V_{lc} K_3 + \frac{V_m}{T_m} \left( P_b + \frac{\Delta H}{13.6} \right) \right]}{60 \theta v_s P_s A_n} \quad (8-8)$$

9. Expression as it appears in 40 CFR 60 Appendix A:

$$\%I = \frac{100 T_s \left[ V_{lc} K_3 + \frac{V_m}{T_m} \left( P_b + \frac{\Delta H}{13.6} \right) \right]}{60 \theta v_s P_s A_n} \quad (8-9)$$

10. An alternate expression for the percent isokinetic obtained from intermediate units is:

$$\%I = K \frac{T_s V_{m(\text{std})}}{4 P_s v_s A_n \theta (1 - B_{ws})} \quad K = 0.09450 \text{ for English units} \quad (8-10)$$

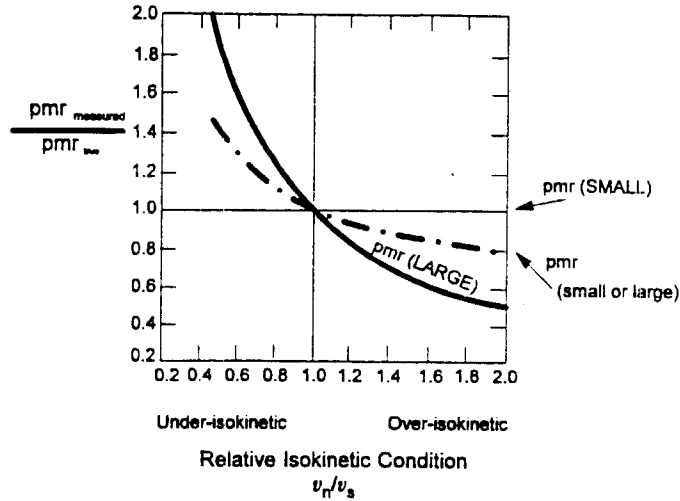

Figure 8-1. Errors due to anisokinetic conditions

## **Notes**

## Notes

# **Lesson 9**

## **Particulate Matter Sampling Train Configurations**

### **Lesson Goal**

The goal of this lesson is to describe different sampling train set-ups and how their design affects what is collected.

### **Lesson Objectives**

Upon completion of this lesson, you should be able to:

1. State the EPA definition of particulate matter for fossil-fuel fired steam generators.
2. Discuss how the design of a sampling train defines what is collected as particulate matter.
3. Describe how the Method 5, Method 17, and Method 8 source sampling trains differ from each other.
4. Discuss how the PM<sub>10</sub> exhaust gas recycle sampling train works.
5. Discuss how the PM<sub>10</sub> constant rate sampling procedure is conducted.

## Lesson 9

### Course 450

Definition of Particulate Matter  
Sampling Train Configurations

09-01

### Filter Temperatures - Method 5

Method 5 -  $248^{\circ}\text{F} \pm 25^{\circ}\text{F}$

Method 5A -  $108^{\circ}\text{F} \pm 18^{\circ}\text{F}$   
(Asphalt plants)

Method 5F -  $320^{\circ}\text{F} \pm 25^{\circ}\text{F}$   
(Nonsulfate particulate matter)

09-02

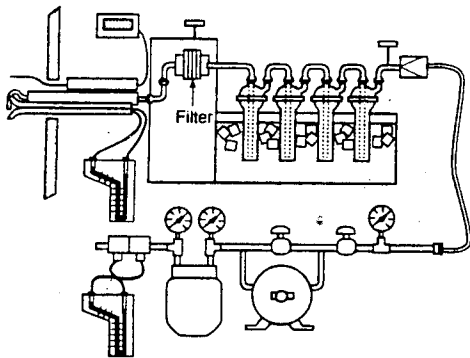

09-03

### Method 8

#### Applicability

Determination of sulfuric acid mist  
and sulfur dioxide (acid plants)

09-04

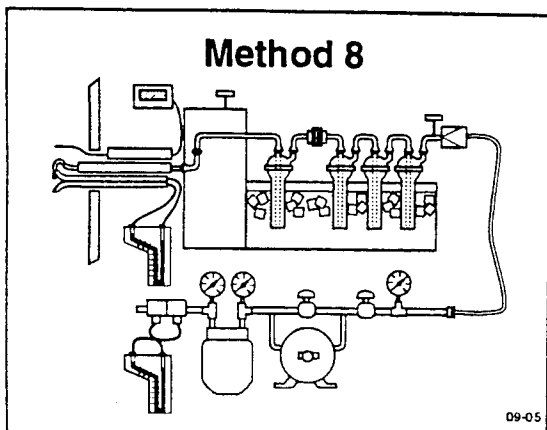

**Method 17**

**In-stack Filter  
Applicability**

In sources where particulate matter  
concentration is independent of  
temperature

09-06

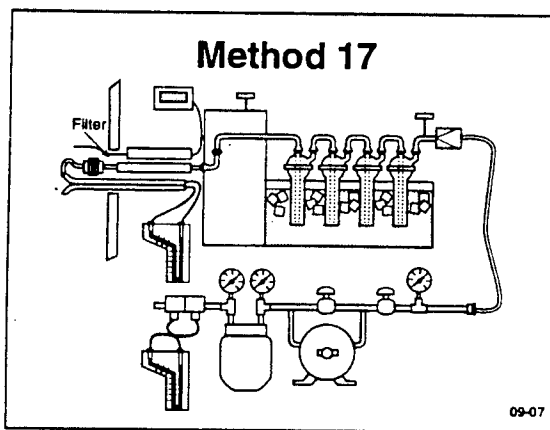

**Method 201**

PM<sub>10</sub> Sampling Train  
Exhaust Gas Recycle  
Procedure (EGR)

40 CFR 51: Appendix M

09-08



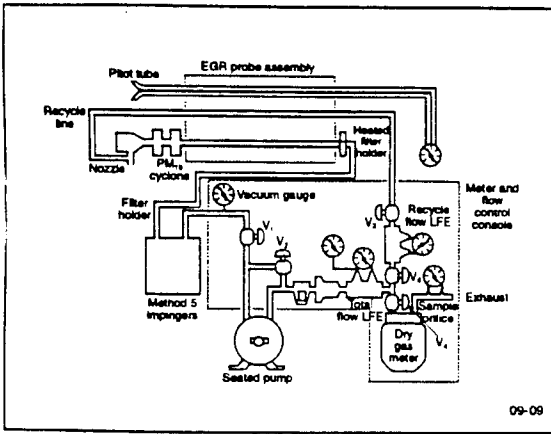

### Method 201A

#### PM<sub>10</sub> Sampling Train Constant Sampling Rate Procedure (CSR)

40 CFR 51: Appendix M

09-10

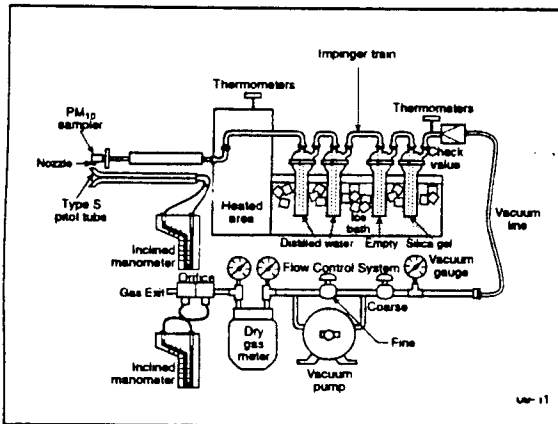

# ***Lesson 10***

## ***Source Sampling Field Procedures***

### ***Lesson Goal***

The goal of this lesson is to explain how a Method 5 source test is designed, planned, and performed.

### ***Lesson Objectives***

Upon completion of this lesson, you should be able to:

1. List the steps involved in getting ready for a Method 5 source test.
2. Describe the activities that are conducted on site prior to performing the actual test.
3. Describe the activities that are performed during the test.
4. List the major activities that are performed on site after the test has been conducted.
5. Tell what calculations must be performed after the source test.
6. List the major topic heading of a source test report.

# Getting Ready

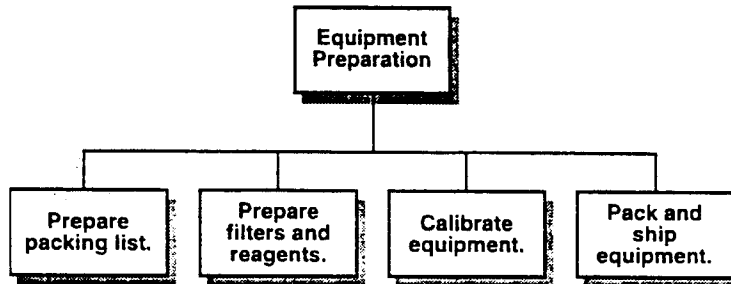
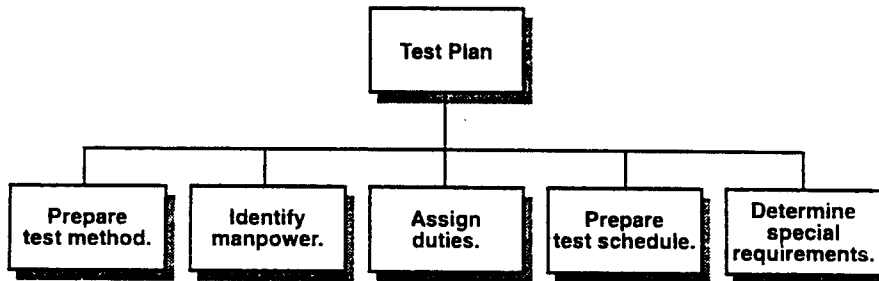
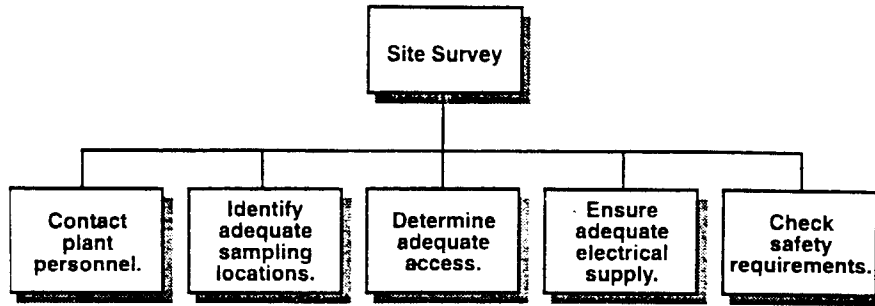

## On-site Activities

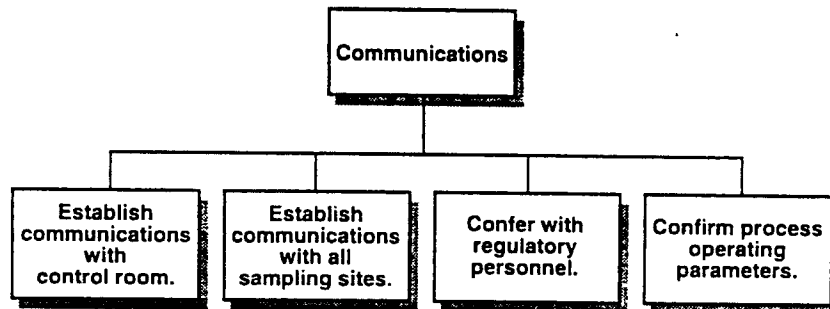
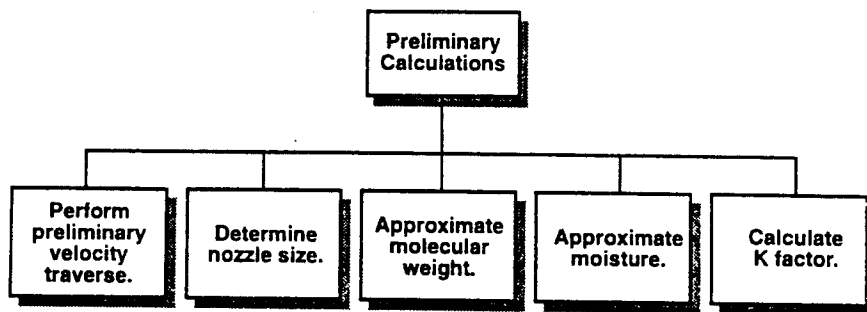
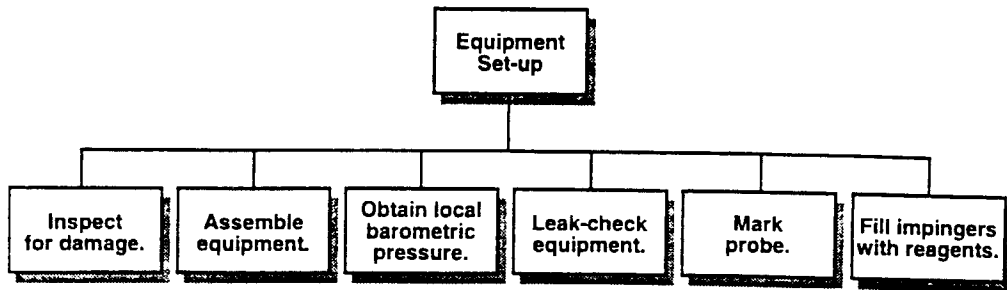

# The Test

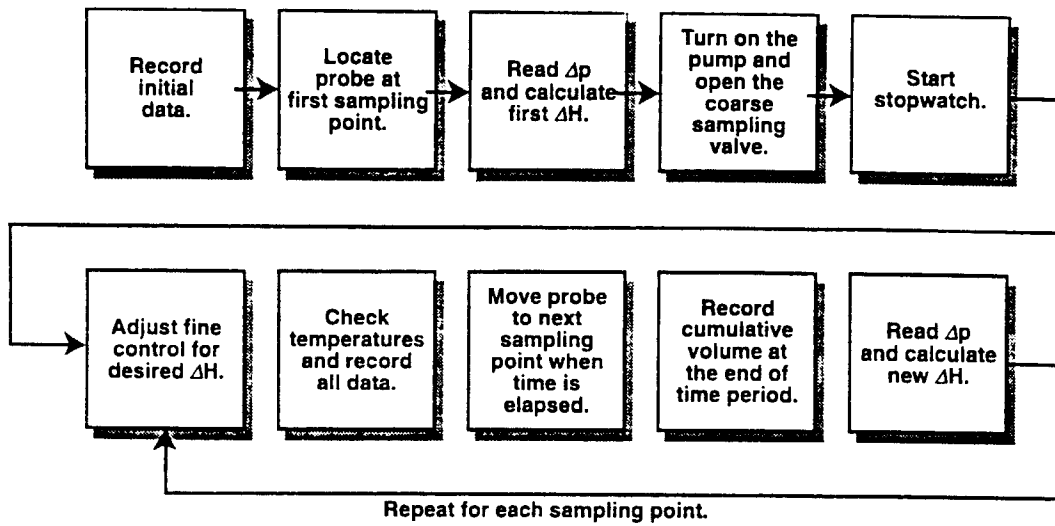

## Post-test Activities

### Sample Recovery - Probe/Nozzle

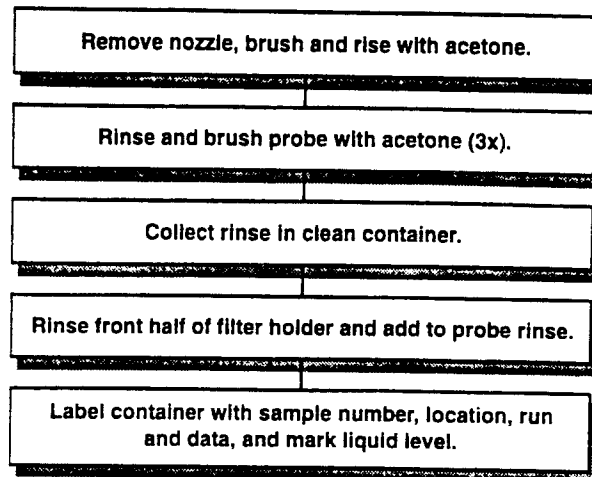

### Sample Recovery - Filter

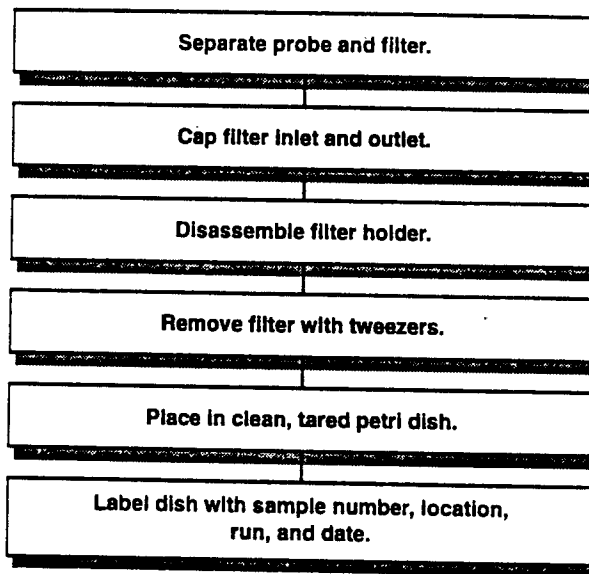

### Sample Recovery - Wrap-up

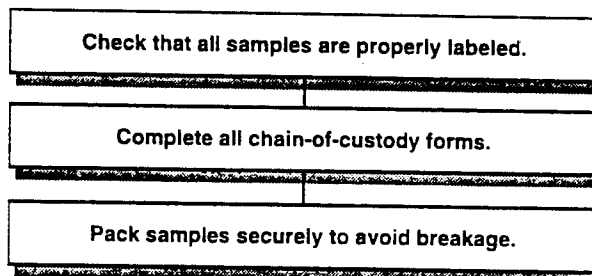

## Post-test Activities (cont.)

### Sample Analysis - Impingers

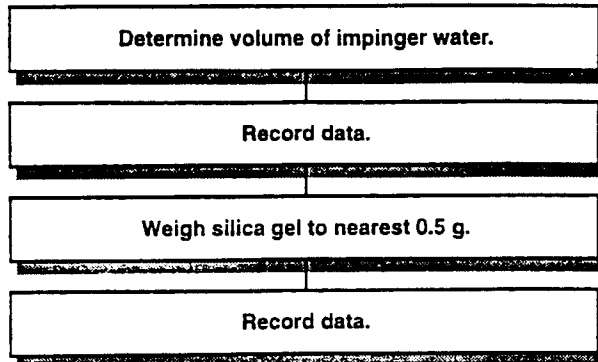

### Sample Analysis - Filters

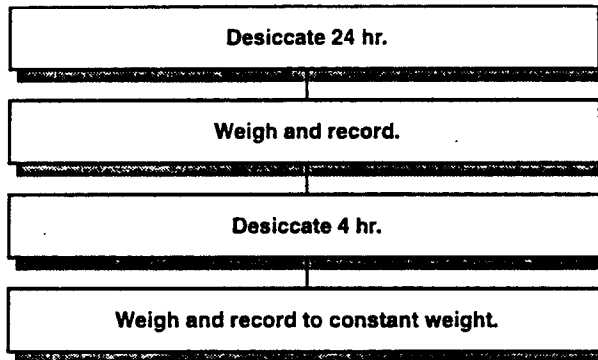

### Sample Analysis - Probe Wash

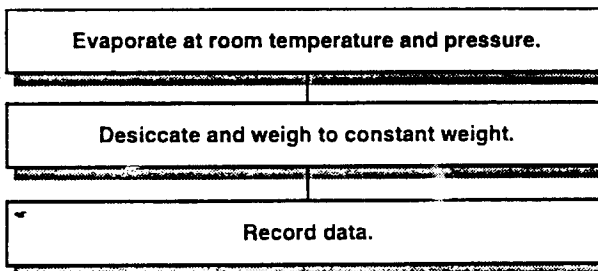

## Post-test Activities

### Final Calculations

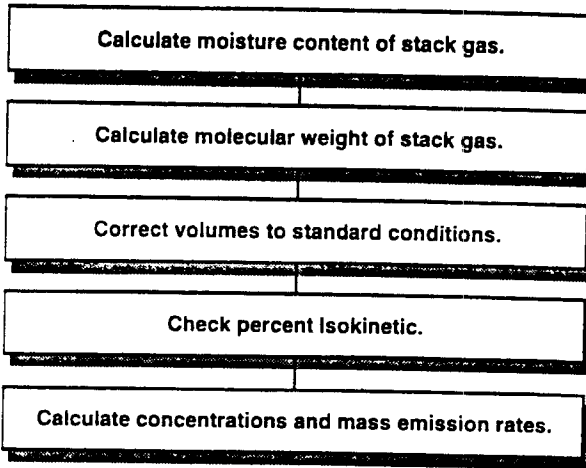

### Reporting

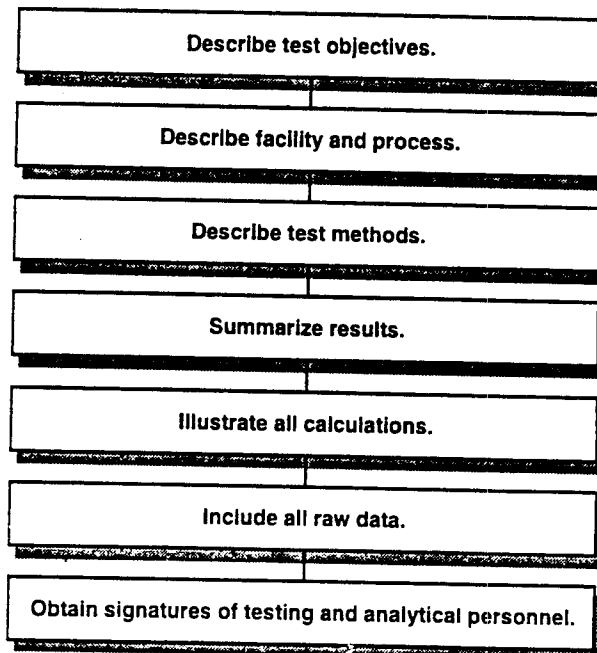



## ***Third Day Laboratory Exercise***

In this laboratory, you and your assigned group will be performing a Method 5 source test. The laboratory exercise directions are given in Appendix A (Laboratory Exercises) of this workbook.

Take notes here for background information and any special instructions given by the Course Director or Laboratory Instructors.

## Notes

## Notes

# **Homework and Laboratory 3 Review**

## **Question-and-Answer Session**

### **Session Goal**

The goal of this session is to review the results of Laboratory 3, the homework assignment, and the pretest, as well as to provide you with the opportunity to discuss any questions or issues presented in the previous day's lectures or laboratory.

### **Session Objectives**

After completing this review, you will be able to do the following:

1. Meet the goals and objectives of yesterday's sessions.
2. Perform calculations similar to those provided in the Homework Exercise.

Laboratory Data Summary														
Group	No. sample pt.	Time min.	$A_s$ ft <sup>2</sup>	$A_n$ ft <sup>2</sup>	$B_{ws}$	$M_s$ lb/lb-mole	$P_s$ in. Hg	$v_s$ ft/sec	$Q_s$ dscf	$V_m$ std	% l	$c_s$ gr/ft <sup>3</sup>	pmr lb/hr	E lbs/10 <sup>6</sup> Btu
1														
2														
3														
4														
5														
6														

If each group was sampling the same duct, why do the results differ? \_\_\_\_\_

\_\_\_\_\_

\_\_\_\_\_

## Notes

## Notes

# **Lesson 11**

## **Error Analysis**

### ***Lesson Goal***

The goal of this lesson is to discuss the distinctions between error and precision and to review the types of error that can occur in a source test.

### ***Lesson Objectives***

Upon completion of this lesson, you should be able to:

1. Explain the difference between precision and accuracy.
2. List and describe three categories of error.
3. Discuss how precise Methods 2-5 are.



# Lesson 11

## Course 450

### Error Analysis

11-01

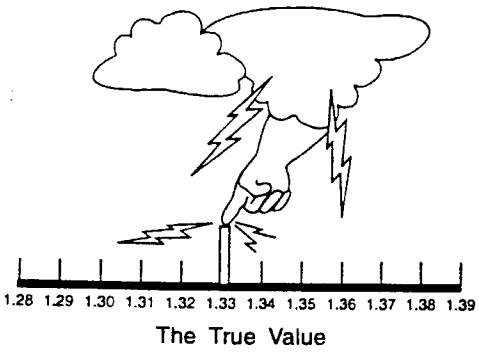

11-02

### Precision and Accuracy

Precision refers to reproducibility.

Accuracy refers to correctness.

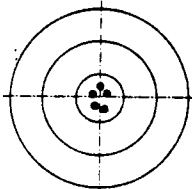
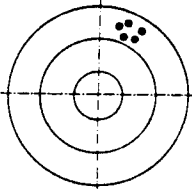

A Precision is good but accuracy is poor.

B Both precision and accuracy are good.

11-03

- 1 Systematic Errors
- 2 Random Errors
- 3 Illegitimate Errors

11-04

# **Lesson 12**

## **Reporting in Units of the Standard**

### **Lesson Goal**

The goal of this lesson is to explain the different formats in which source test data can be reported, using concentration correction and F factor equations.

### **Lesson Objectives**

Upon completion of this lesson, you should be able to:

1. Correct a particulate concentration to standard temperature and pressure.
2. Correct a particulate concentration to 12% CO<sub>2</sub>.
3. Correct a particulate concentration to 6% O<sub>2</sub>.
4. Correct a particulate concentration to 50% excess air.
5. Define what an F factor is and how it is used to compute the emission rate for combustion sources.
6. Identify at least three F factor methods.
7. Use F factors for cross-checking Method 3 data and combustion data.

## Lesson 12

### Course 450

#### Reporting in Units of the Standard

12-01

$$\bar{c}_s = \bar{c}_{\text{corr}} = c_s \frac{P_{\text{std}} T_s}{P_s T_{\text{std}}}$$

12-02

$$\bar{c}_{s_{12}} = \bar{c}_s \frac{12}{\%CO_2}$$

12-03

$$\bar{c}_{s_{O_2}} = \frac{\bar{c}_s [20.9 - 6.0]}{20.9 - \%O_2}$$

12-04

$$\%EA = \frac{V_{EA}}{V_{\text{required for complete combustion}}} \times 100$$

12-05

$$\%EA = \frac{\%O_2 - 0.5 (\%CO)}{0.264(\%N_2) - [\%O_2 - 0.5 (\%CO)]} \times 100$$

12-06

### Method 19 F Factor Methods

12-07

$$E = \frac{pmr_s}{Q_H} = \frac{c_s Q_s}{Q_H} = \frac{\frac{\text{lbs-ft}^3}{\text{ft}^3 \cdot \text{hr}}}{10^6 \text{ Btu/hr}}$$

$$= \frac{\text{lbs}}{10^6 \text{ Btu}}$$

12-08

$$E = c_s F \left( \begin{array}{c} \text{dilution} \\ \text{correction} \\ \text{term} \end{array} \right)$$

12-09

$$E = \frac{\cancel{ft^3} \text{ lbs}}{10^6 \text{ Btu } \cancel{ft^3}} = \frac{\text{lbs}}{10^6 \text{ Btu}}$$

Dilution correction term is dimensionless.

12-10

$$E = \bar{c}_s F_d \left[ \frac{20.9}{20.9 - \%O_2} \right]$$

12-11

$$E = c_{ws} F_d \left[ \frac{20.9}{20.9(1 - B_{ws}) - \%O_{2w}} \right]$$

12-12

$$E = \bar{c}_s F_c \frac{100}{\%CO_2}$$

12-13

$$E = \bar{c}_{sw} F_w \left[ \frac{20.9}{20.9(1 - B_{wa}) - \%O_{2w}} \right]$$

12-14

Table 19-1-F: Factors for Various Fuels<sup>1</sup>

Fuel Type	F <sub>s</sub>		F <sub>w</sub>		F <sub>o</sub>	
	secmJ	sec/10 <sup>3</sup> Btu	whomJ	whoc/10 <sup>3</sup> Btu	comJ	oc/10 <sup>3</sup> Btu
Coal						
Anthracite <sup>2</sup> .....	2.71x10 <sup>-3</sup>	10,100	2.83x10 <sup>-3</sup>	10,840	2.71x10 <sup>-3</sup>	1,070
Bituminous <sup>2</sup> .....	2.63x10 <sup>-3</sup>	9,780	2.66x10 <sup>-3</sup>	10,040	2.63x10 <sup>-3</sup>	1,000
Lignite .....	2.65x10 <sup>-3</sup>	9,860	3.21x10 <sup>-3</sup>	10,950	2.65x10 <sup>-3</sup>	1,010
Oil						
Oil <sup>3</sup> .....	2.47x10 <sup>-3</sup>	9,190	2.77x10 <sup>-3</sup>	10,320	2.47x10 <sup>-3</sup>	1,420
Gas						
Natural .....	2.43x10 <sup>-3</sup>	8,710	2.85x10 <sup>-3</sup>	10,610	2.43x10 <sup>-3</sup>	1,040
Propane .....	2.34x10 <sup>-3</sup>	8,710	2.74x10 <sup>-3</sup>	10,200	2.34x10 <sup>-3</sup>	1,190
Butane .....	2.34x10 <sup>-3</sup>	8,710	2.79x10 <sup>-3</sup>	10,300	2.34x10 <sup>-3</sup>	1,250
Wood						
Wood bark .....	2.48x10 <sup>-3</sup>	9,240			2.48x10 <sup>-3</sup>	1,030
Wood chips .....	2.58x10 <sup>-3</sup>	9,600			2.58x10 <sup>-3</sup>	1,020
Municipal <sup>4</sup> .....	2.57x10 <sup>-3</sup>	9,570			2.57x10 <sup>-3</sup>	1,020
Solid Waste						

<sup>1</sup> Determined at standard conditions: 30° C (86° F) and 760 mm Hg (29.92 in. Hg).  
<sup>2</sup> As specified according to ASTM D2869-77.  
<sup>3</sup> Crude, residual, or middle.

12-15



# **Lesson 13**

## **Source Sampling Quality Assurance and Safety on the Sampling Site**

### **Lesson Goal**

The goal of this lesson is to discuss the aspects of the source test procedures that affect data quality and the safety of the source tester at the sampling site.

### **Lesson Objectives**

Upon completion of this lesson, you should be able to:

1. List at least 20 procedures that are necessary for good quality data to be obtained.
2. Describe how the basic components of the Method 5 sampling train are calibrated.
3. Discuss how a critical orifice can be used to audit a Method 5 sampling train.
4. Recognize at least 10 causes of accidents in source testing.
5. Discuss the importance of an accident analysis program.



**Lesson 13**

**Course 450**

Source Sampling, Quality Assurance,  
and On-Site Safety

13-01

**Quality Assurance Handbook  
for Air Pollution  
Measurement Systems**

Volume III  
Stationary Source  
Specific Methods

EPA 600/4-77-027b

13-02

**EPA APTI  
Correspondence Course 414**

EPA 450/2-82-003

13-03

**Source Testing QA**

- Calibrate
- Calibrate
- Calibrate
- Leak Check
- Leak Check
- Leak Check

13-04

Break into groups and list at least 20 observations that a source test observer should make that would enable him or her to evaluate whether the test team will be obtaining good quality data.

1. \_\_\_\_\_
2. \_\_\_\_\_
3. \_\_\_\_\_
4. \_\_\_\_\_
5. \_\_\_\_\_
6. \_\_\_\_\_
7. \_\_\_\_\_
8. \_\_\_\_\_
9. \_\_\_\_\_
10. \_\_\_\_\_
11. \_\_\_\_\_
12. \_\_\_\_\_
13. \_\_\_\_\_
14. \_\_\_\_\_
15. \_\_\_\_\_
16. \_\_\_\_\_
17. \_\_\_\_\_
18. \_\_\_\_\_
19. \_\_\_\_\_
20. \_\_\_\_\_

## Method 5 Quality Control Procedures

13-05

### Component Calibration

#### Probe Nozzle

- Measure three diameters of the nozzle.
- Calculate the average measurement.
- The difference between the high and low measurement shall not exceed 0.004 in.
- Nozzle should be uniquely identified.

13-06

### Probe Heater Calibration

Calibrate probe heater if not constructed according to APTD - 0581 using procedure outlined in APTD - 0576.

13-07

### Pitot Tube Calibration

Perform dimensional specification test  
and/or

Calibrate in wind tunnel against standard pitot tube (preferably with NBS traceable coefficient).

13-08

### Impinger Thermometer

Calibrate with a mercury-in-glass thermometer that meets STM E-1 No. 63C or 63F specifications.

- Compare readings in ice bath.
- Compare readings at room temperature.
- Thermometer must agree within 2° F of the reference thermometer at both temperatures.

13-09

### Dry Gas Meter Thermometer

Calibrate with a mercury-in-glass thermometer that meets ASTM specifications.

- Compare readings in hot water bath 105° - 122° F.
- Compare readings at room temperature.
- Thermometers must agree within 5.4° F at both points or differential at both points within 5.4° F.

13-10

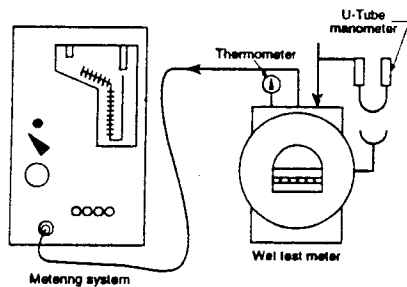

Equipment arrangement for metering system calibration

13-11

### Balance Calibration

#### Analytical Balance

Calibrate using Class-S weights (balance should agree within  $\pm 2$  mg).

#### Trip Balance

Calibrate using Class-S weights (balance should agree within  $\pm 0.5$  g).

13-12

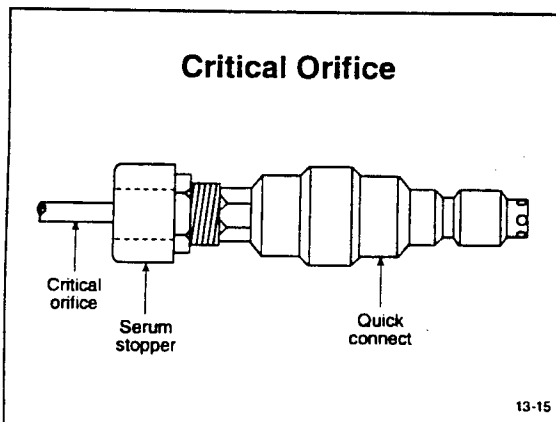
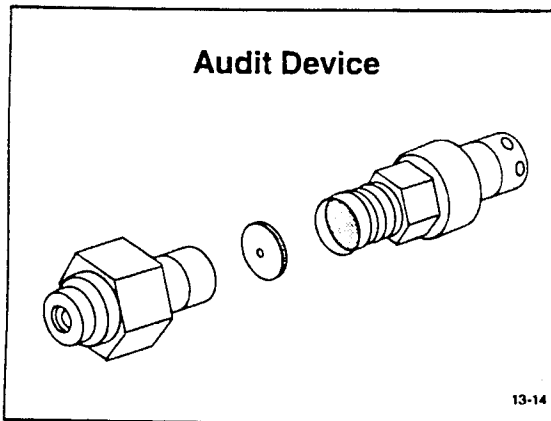
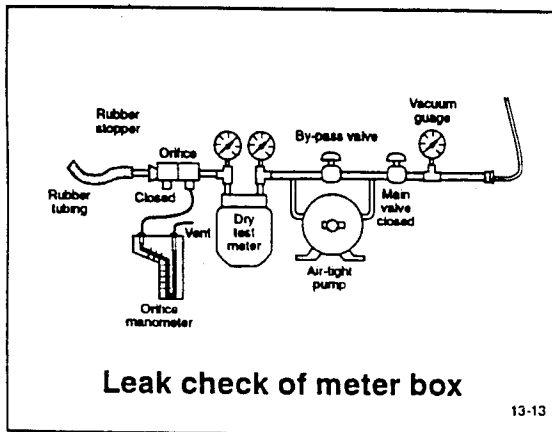

- Leak Checks**
- Pitot tube lines
  - Probe
  - Sample lines
  - Filter
  - Metering system
- 13-16

## **Safety on the Sampling Site**

### **The Importance of an Accident Analysis Program**

13-17

## **Causes of Accidents**

- Poor instruction
- Poor planning
- Improper design
- Proper equipment not provided
- Failure to follow instructions

13-18

## **Causes of Accidents** (Continued)

- Neglect or improper use of equipment
- Faulty equipment
- Untrained personnel
- Uncooperative personnel
- Unpredictable outside agents

13-19

## **Personal Safety Equipment**

- Hard hat
- Safety glasses
- Safety shoes
- Respirators
- Gloves
- Proper clothing
- Safety belt (harness)
- First aid kit

13-20



# **Section 14**

## **Literature Sources**

### **Lesson Goal**

To discuss other sources of information on source sampling and environmental control.

### **Lesson Objectives**

Upon completion of this lesson, you should be able to:

1. List at least three periodicals in which source testing and environmental control information can be found.
2. Identify the professional organizations that encourage the dissemination of source testing information.
3. Identify the types of information that are available on the EMTIC bulletin board.



## ***Periodicals***

## ***Professional Organizations***

## ***Publications***

## ***EMTIC Bulletin Board***

Phone No. (1200 or 2400 bps modem) \_\_\_\_\_

Phone No. (9600 bps modem) \_\_\_\_\_

Data bits: \_\_\_\_\_

Parity: \_\_\_\_\_

Stop bits: \_\_\_\_\_

# **Lesson 15**

## ***Advanced Topic Lecture***

### ***Lesson Goal***

The goal of this lesson is to introduce you to an advanced topic in source testing, such as particle sizing, continuous mass measurement, or PM<sub>10</sub> sampling.

### ***Lesson Objectives***

Upon completion of this lesson, you should be able to:

1. Discuss the application of the procedures discussed.
2. Explain how the techniques are conducted.

## Notes

## **Notes**

## Notes

# ***Appendix A***

## ***First Day Laboratory Exercises***

# First Day Laboratory Exercise 1

## Traverse Point Determination

### Laboratory Objective

Upon completion of this laboratory exercise, you should be able to:  
Determine the number and the location of the traverse points at your assigned sampling site.

### Introduction

Mark your sampling site location on the following diagram of the APTI Course 450 sampling duct and then follow the procedures given.

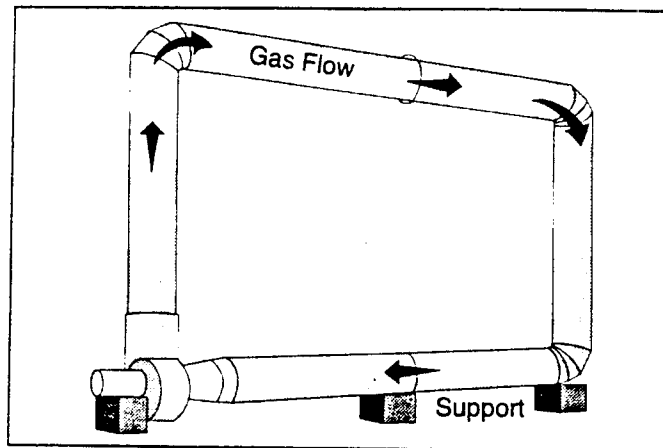

Figure A-1. APTI course 450 sampling duct

### Procedures

For detailed regulatory instructions, refer to Method 1, in Appendix B of the APTI Course 450 Student Manual.

#### A. Determination of the minimum number of traverse points:

Step 1. Measure the inside dimensions of the duct at the sampling site. Sampling ports have been installed in the laboratory ductwork. Use the port assigned to your laboratory group.

Record this data on the Exercise 1 Hand-in Sheet (page A-5).

Step 2. Determine the distance of the sampling port from upstream and downstream flow disturbances.

Record this data on the Exercise 1 Hand-in Sheet (page A-5).

Step 3. Determine the number of traverse points for a velocity determination using Figure A-2.

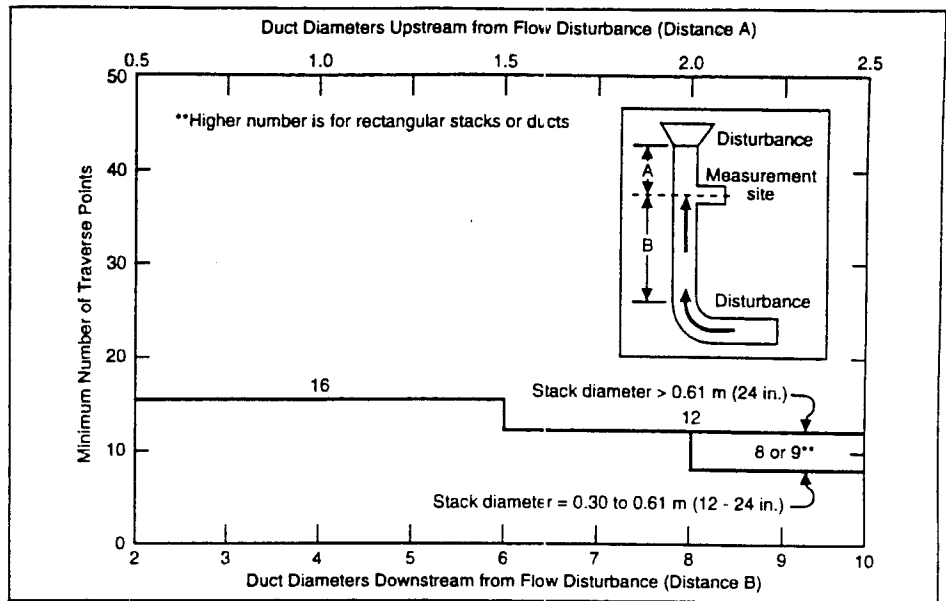

Figure A-2. Minimum number of traverse points for velocity (nonparticulate) traversers

Step 4. Determine the number of traverse points for a particulate traverse using Figure A-3.

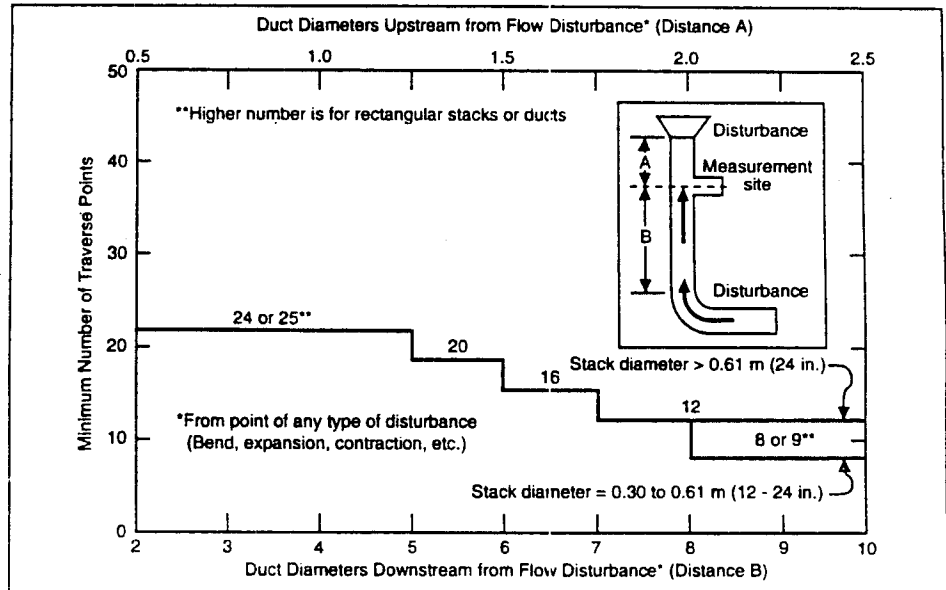

Figure A-3. Minimum number of traverse points for particulate traverses



B. Determination of traverse point locations

Step 1. Determine the locations for the velocity traverse points using Table A-1.

Table A-1. Location of Traverse Points in Circular Stacks (Percent of stack diameter from inside wall to traverse point)												
Traverse point on a diameter	Number of traverse points on a diameter											
	2	4	6	8	10	12	14	16	18	20	22	24
1	14.6	6.7	4.4	3.2	2.6	2.1	1.8	1.6	1.4	1.3	1.1	1.1
2	85.4	25.0	14.6	10.5	8.2	6.7	5.7	4.9	4.4	3.9	3.5	3.2
3		75.0	29.6	19.4	14.6	11.8	9.9	8.5	7.5	6.7	6.0	5.5
4		93.3	70.4	32.3	22.6	17.7	14.6	12.5	10.9	9.7	8.7	7.9
5			85.4	67.7	34.2	25.0	20.1	16.9	14.6	12.9	11.6	10.5
6			95.6	80.6	65.8	35.6	26.9	22.0	18.8	16.5	14.6	13.2
7				89.5	77.4	64.4	36.6	28.3	23.6	20.4	18.0	16.1
8				96.8	85.4	75.0	63.4	37.5	29.6	25.0	21.8	19.4
9					91.8	82.3	73.1	62.5	38.2	30.6	26.2	23.0
10					97.4	88.2	79.9	71.7	61.8	38.8	31.5	27.2
11						93.3	85.4	78.0	70.4	61.2	39.3	32.3
12						97.9	90.1	83.1	76.4	69.4	60.7	39.8
13							94.3	87.5	81.2	75.0	68.5	60.2
14							98.2	91.5	85.4	79.6	73.8	67.7
15								95.1	89.1	83.5	78.2	72.8
16								98.4	92.5	87.1	82.0	77.0
17									95.6	90.3	85.4	80.6
18									98.6	93.3	88.4	83.9
19										96.1	91.3	86.8
20										98.7	94.0	89.5
21											96.5	92.1
22											98.9	94.5
23												96.8
24												98.9

Step 2. Determine the locations for the particulate measurement traverse points using Table A-1.

Step 3. If the duct diameter is less than 12 in., make any necessary corrections for small diameter ducts (if you need to do this, refer to Method 1, reproduced in Appendix B of the course manual.)

Step 4. Record all data on the Exercise 1 Hand-in Sheet (page A-5).  
(There is a duplicate Exercise Hand-in Sheet that you may keep in your workbook for future reference.)

Step 5. Proceed to the next available Lab Exercise Station.

Name \_\_\_\_\_  
 Group No. \_\_\_\_\_  
 Date \_\_\_\_\_

## Exercise 1 Hand-in Sheet

### Number and Location of Traverse Points

A. Number of Traverse Points

Port number \_\_\_\_\_  
 Location \_\_\_\_\_  
 Duct diameter \_\_\_\_\_  
 Number of duct diameters from  
 upstream disturbance \_\_\_\_\_  
 Number of duct diameters from  
 downstream disturbance \_\_\_\_\_  
 Number of traverse points on a diameter \_\_\_\_\_

B. Traverse Point Locations

% of Diameter	Diameter 1 Distance from Inside Wall	Diameter 2 Distance from Inside Wall
_____	_____	_____
_____	_____	_____
_____	_____	_____
_____	_____	_____
_____	_____	_____
_____	_____	_____
_____	_____	_____
_____	_____	_____
_____	_____	_____
_____	_____	_____
_____	_____	_____
_____	_____	_____
_____	_____	_____
_____	_____	_____
_____	_____	_____
_____	_____	_____
_____	_____	_____
_____	_____	_____
_____	_____	_____
_____	_____	_____

C. Illustration of Sample Point Locations

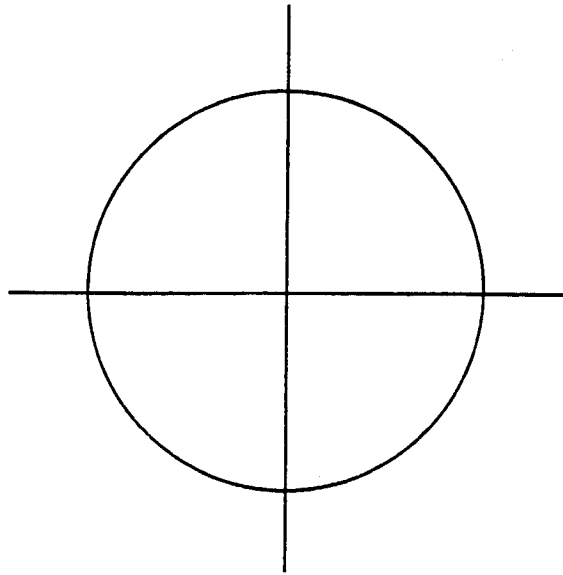

*Note:* Before turning in this hand-in sheet, record your data on the following duplicate hand-in sheet. Keep the duplicate in your workbook for future reference.

Name \_\_\_\_\_  
 Group No. \_\_\_\_\_  
 Date \_\_\_\_\_

## **Exercise 1 Hand-in Sheet**

*(Duplicate: Keep in your workbook for future reference)*

### **Number and Location of Traverse Points**

**A. Number of Traverse Points**

Port number \_\_\_\_\_

Location \_\_\_\_\_

Duct diameter \_\_\_\_\_

Number of duct diameters from  
upstream disturbance \_\_\_\_\_

Number of duct diameters from  
downstream disturbance \_\_\_\_\_

Number of traverse points on a diameter \_\_\_\_\_

**B. Traverse Point Locations**

<b>% of Diameter</b>	<b>Diameter 1 Distance from Inside Wall</b>	<b>Diameter 2 Distance from Inside Wall</b>
_____	_____	_____
_____	_____	_____
_____	_____	_____
_____	_____	_____
_____	_____	_____
_____	_____	_____
_____	_____	_____
_____	_____	_____
_____	_____	_____
_____	_____	_____
_____	_____	_____
_____	_____	_____
_____	_____	_____
_____	_____	_____
_____	_____	_____
_____	_____	_____
_____	_____	_____
_____	_____	_____
_____	_____	_____
_____	_____	_____
_____	_____	_____
_____	_____	_____
_____	_____	_____
_____	_____	_____

C. Illustration of Sample Point Locations

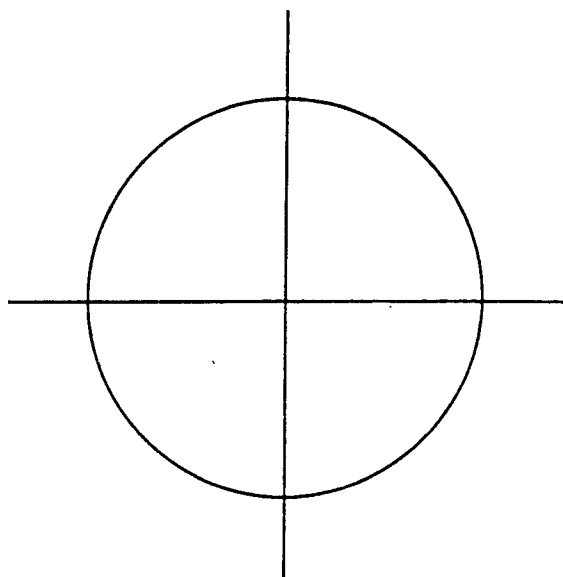

# First Day Laboratory Exercise 2

## Pitot Tube Calibration

### Laboratory Objective

Upon completion of this laboratory exercise you should be able to:  
Determine the pitot tube calibration coefficient,  $C_p$ , for a Stausscheibe type (Type S) pitot tube, using a standard pitot tube as a reference and a laboratory test duct.

### Introduction

This exercise will be performed at two laboratory work stations on the laboratory duct. Your instructor will show at which ports the exercise will be conducted.

Depending upon the equipment available, you may be using either a bare pitot tube or a pitot tube attached to a sample probe. In either case, determine the  $C_p$  for both the A and B sides of the tube. Use the manometer supplied or the meter box manometer. Figure A-4 illustrates the exercise set-up.

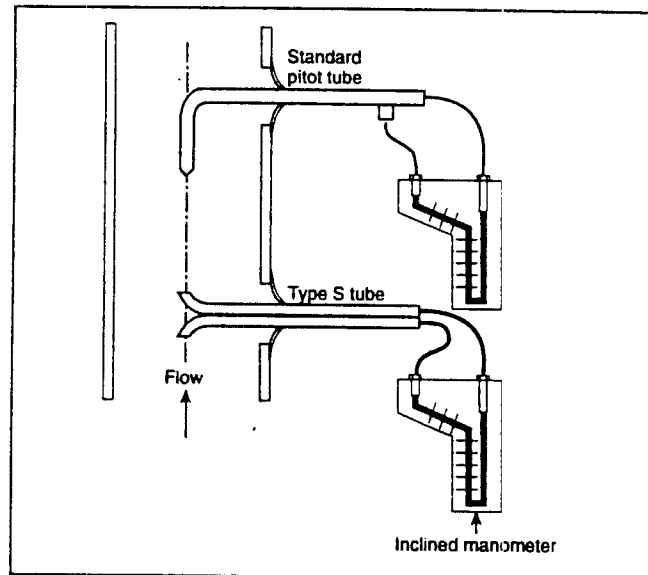

Figure A-4. Test arrangement for pitot tube calibration

### Procedures

- Step 1. Go to one of the assigned test stations.
- Step 2. At the test station, note two holes in the ductwork. Note that one is for the Type S pitot tube and the other for the standard pitot tube. The hole should be located in such a manner that the tip of the standard pitot tube will be measuring at the same location as the Type S pitot tube.

- Step 3. Set-up, level, and zero the inclined manometer. Make sure that any valves on the manometer are in the "open" position.
- Step 4. Label one leg of the Type S pitot tube as "A" and the other leg as "B."
- Step 5. Determine the distance from the center of the duct to the outside wall of the duct. Insert the pitot tube so that the center of the impact tube is located at the center of the duct. Place a mark on the tube such that when the mark is placed at the outside edge of the duct, the tip of the pitot tube is at the center of the duct.
- Step 6. Repeat Step 5 for the standard pitot tube.
- Step 7. Connect the pitot tube to the manometer as shown in Figure A-5, or to the manometer of the meter box as shown by your instructor.
- Step 8. Insert the pitot tube into the duct until the mark is at the outside edge of the duct wall.
- Step 9. Align the pitot tube so that the "A" leg faces directly into the flow stream. Tape the hole shut with duct tape to minimize air leakage into the duct.

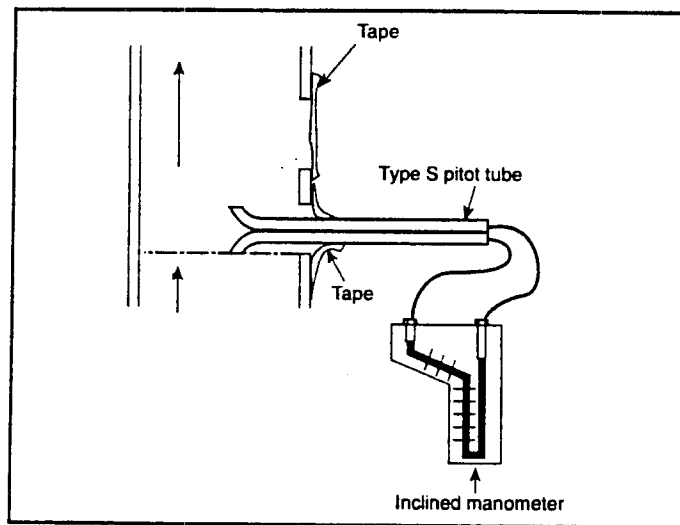

Figure A-5. Test arrangement for Type S pitot tube

- Step 10. On the Exercise 2 Hand-in Sheet (page A-12), record the  $\Delta p$  in inches of  $H_2O$  indicated by the manometer. (There is a duplicate Exercise Hand-in Sheet that you may keep in your workbook for future reference.)
- Step 11. Disconnect the pitot tube lines from the Type S pitot tube and attach them to the standard pitot tube as shown in Figure A-6 (or to the meter box as shown by your instructor).

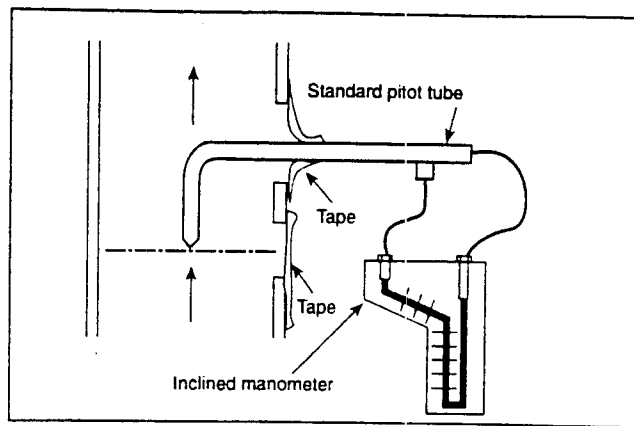

Figure A-6. Test arrangement for standard pitot tube

- Step 12. Insert the standard pitot tube into the duct until the mark is at the outside edge of the duct wall, as shown in Figure A-6.
- Step 13. Align the tube so that it faces directly into the flow stream and the center of the tube is in exactly the same location in the duct as the Type S pitot tube was.
- Step 14. On the Exercise 2 hand-in Sheet (page A-12), record the  $\Delta p$  in inches of  $H_2O$  indicated by the manometer.
- Step 15. Determine the pitot tube coefficient according to the following equation:

$$C_p = C_p (\text{standard}) \sqrt{\frac{\Delta p (\text{standard})}{\Delta p (\text{Type S})}}$$

Assume:  $C_p (\text{standard}) = 0.99$

Record this result on the Exercise 2 Hand-in Sheet (page A-12).

- Step 16. Repeat Steps 7-15 for the B side of Type S pitot tube. *Note:* This means that you must also obtain another measurement with the standard tube. Don't skip Steps 11-13.
- Step 17. Perform a second calibration run by repeating Steps 7-16.
- Step 18. Perform a third calibration run by repeating Steps 7-16.
- Step 19. Obtain the average  $C_p$  for leg A and leg B of the Type S pitot tube and record the result on the Exercise 2 Hand-in Sheet (page A-12).





Name \_\_\_\_\_  
 Group No. \_\_\_\_\_  
 Date \_\_\_\_\_

## Exercise 2 Hand-in Sheet

### Calibration of Type S Pitot Tube

Probe-Type S Pitot Tube: ID No. \_\_\_\_\_

NBS Standard Pitot-Static Tube  $C_p = 0.99$

Type S Pitot Tube Coefficient Data					
	Legs A, B of Type S Pitot Tube	Standard Pitot- Static Tube $\Delta p$ in. H <sub>2</sub> O	Type S Pitot Tube $\Delta p$ in. H <sub>2</sub> O	$C_{p(s)}$ Leg A	$C_{p(s)}$ Leg B
Test 1	A				
	B				
Test 2	A				
	B				
Test 3	A				
	B				
			$\bar{C}_p$		

$$C_{p(s)} = \left[ \frac{\Delta P_{std}}{\Delta p_s} \right]^{1/2} C_{p(std)}$$

*Note:* Before turning in this hand-in sheet, record your data on the following duplicate hand-in sheet. Keep the duplicate in your workbook for future reference.



Name \_\_\_\_\_  
 Group No. \_\_\_\_\_  
 Date \_\_\_\_\_

## Exercise 2 Hand-in Sheet

(Duplicate: Keep in your workbook for future reference)

### Calibration of Type S Pitot Tube

Probe-Type S Pitot Tube: ID No. \_\_\_\_\_

NBS Standard Pitot-Static Tube  $C_p = 0.99$

Type S Pitot Tube Coefficient Data					
	Legs A, B of Type S Pitot Tube	Standard Pitot- Static Tube $\Delta p$ in. H <sub>2</sub> O	Type S Pitot Tube $\Delta p$ in. H <sub>2</sub> O	$C_{p(s)}$ Leg A	$C_{p(s)}$ Leg B
Test 1	A				
	B				
Test 2	A				
	B				
Test 3	A				
	B				
			$\bar{C}_p$		

$$C_{p(s)} = \left[ \frac{\Delta p_{std}}{\Delta p_s} \right]^{1/2} C_{p(std)}$$

# First Day Laboratory Exercise 3

## Determination of Moisture Content by the Wet Bulb-Dry Bulb Technique

### Laboratory Objective

Upon completion of this laboratory exercise, you should be able to:  
Determine the moisture content of the flue gas in the test duct by using an approximation technique the wet bulb-dry bulb method.

### Introduction

This exercise can be performed at any of the ports cut into the test duct. Use the equipment supplied for this exercise.

Figure A-7 shows the exercise set-up.

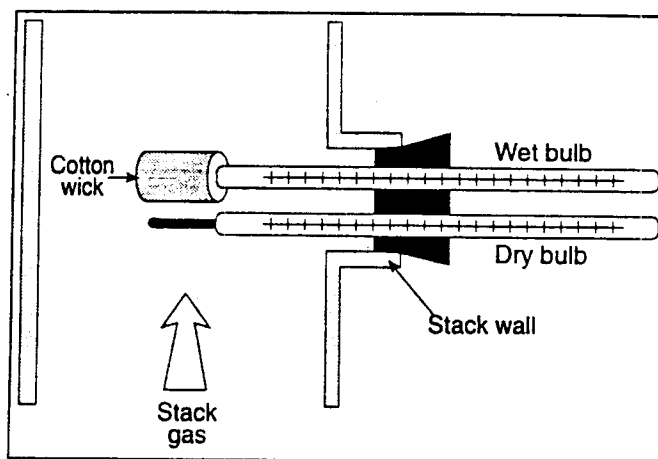

Figure A-7. Test arrangement for wet bulb-dry bulb technique for moisture measurement

### Procedures

- Step 1. Insert the dry bulb thermometer into the duct. Cover the port hole with duct tape or a rag so that air does not leak in. Allow the thermometer to come into equilibrium with the flue gas temperature. Read the temperature indicated by the dry bulb thermometer.

Record the flue gas temperature on the Exercise 3 Hand-in Sheet (page A-22). (There is a duplicate Exercise Hand-in Sheet that you may keep in your workbook for future reference)

- Step 2. The wet bulb thermometer is covered with a cotton wick. Dip the end of the thermometer into water to saturate the wick.

- Step 3. Insert the wet bulb thermometer into the duct and allow the thermometer to come into equilibrium with the flue gas temperature. The temperature reading (as a function of time elapsed) should change in a manner indicated in Figure A-8.

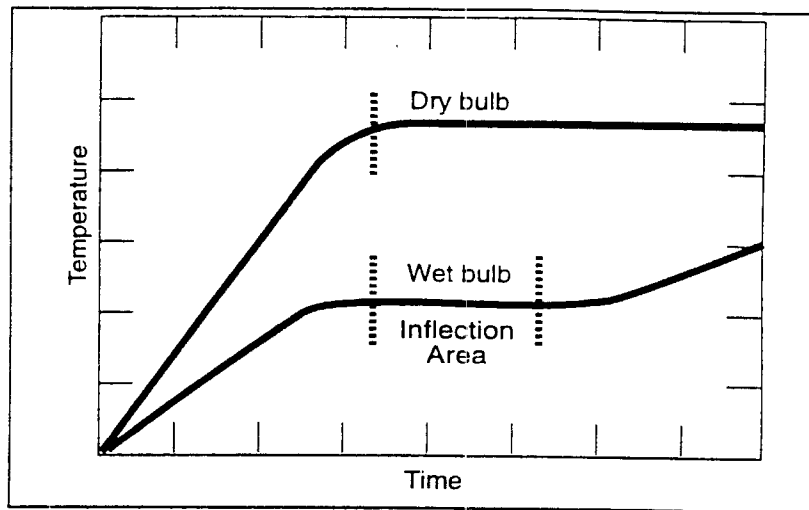

Figure A-8. Equilibrium and inflection points of dry bulb and wet bulb thermometers

- Step 4. The temperature of the wet bulb thermometer will rise to an equilibrium value, and then drying out, will reach the temperature of the flue gas. Read the wet bulb temperature at the first equilibrium value (the inflection point).
- Record this temperature as  $t_{\text{wet bulb}}$  on the Exercise 3 Hand-in Sheet (page A-22).
- Step 5. Obtain a value for the current barometric pressure,  $P_{\text{bar}}$  by either asking the instructor or calling the local weather station.
- Record the value for  $P_{\text{bar}}$  on the Exercise 3 Hand-in Sheet (page A-22).
- Step 6. Obtain a value for  $P_s$ , the stack static pressure, by inserting a standard pitot tube into the center of the duct and measuring the pressure on the static tap of the tube as shown in Figure A-9. If the stack pressure is positive, attach the tube to the left-hand side of the manometer. If the stack pressure is negative, attach the tube to the right-hand side of the manometer.
- Record the value on the Exercise 3 Hand-in Sheet (page A-22).

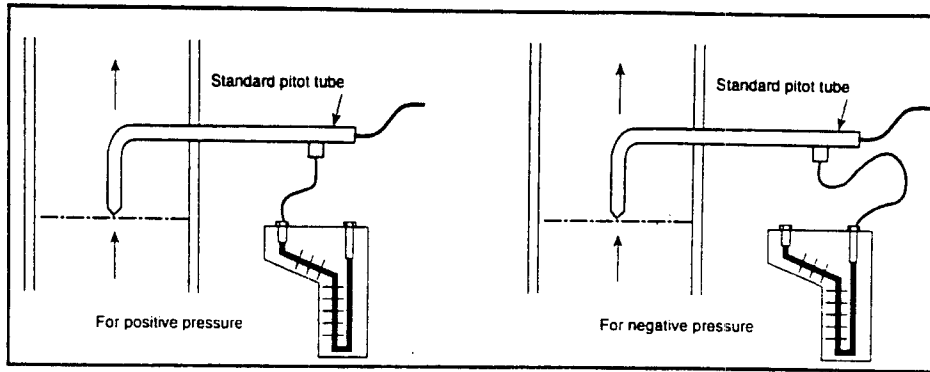

Figure A-9. Arrangement for determining the static pressure,  $P_s$

## Wet Bulb-Dry Bulb Calculations

### 1. Wet bulb-dry bulb moisture determination calculation technique

Moisture content can be calculated using the wet bulb-dry bulb technique, from the following equation:

$$B_{ws} = \frac{v.p.}{P_s} \quad (A-1a)$$

Where: v.p. = vapor pressure of  $H_2O$   
 $P_s$  = absolute pressure of stack gas

First we solve for v. p.:

$$v.p. = s.v.p. - (3.67 \times 10^{-4})(P_s)(t_d - t_w) \left( 1 + \frac{t_w - 32}{1571} \right) \quad (A-1b)$$

Where: s.v.p. = saturated  $H_2O$  vapor pressure at wet bulb temperature taken from Table 5

$t_d$  = temperature of dry bulb measurement °F

$t_w$  = temperature of wet bulb measurement °F

$P_s$  = absolute pressure of stack gas =  $P_{bar} + p_s$

$$\begin{aligned} v.p. &= ( \quad \text{in. Hg} ) - (3.67 \times 10^{-4})( \quad \text{in. Hg} )( \quad - \quad ) \left( 1 + \frac{ \quad - 32 }{ 1571 } \right) \\ &= ( \quad \text{in. Hg} ) - ( \quad \text{in. Hg} ) \\ &= \quad \text{in., Hg} \end{aligned}$$

Next we determine  $P_s$ :

$$P_s = \text{___ in. Hg} + \text{___ in. H}_2\text{O} / 13.6 \frac{\text{in. Hg}}{\text{in. H}_2\text{O}}$$

$$P_s = \text{___ in. Hg}$$

Supplying all unknowns into the equation, we have:

$$B_{ws} = \frac{\text{___ in. Hg}}{\text{___ in. Hg}} = \text{___} \times 100 = \text{___} \% \quad (\text{A-1c})$$

Record this value on Exercise 3 Hand-in Sheet (page A-22).





**Table A-2. Saturated Water Vapor Pressure (Inches of Mercury)**

Wet bulb temp. Degree F	Saturated water vapor pressure (Inches of mercury)									
	0	1	2	3	4	5	6	7	8	9
-20	.0126	.0119	.0112	.0106	.0100	.0095	.0089	.0084	.0080	.0075
-10	.0222	.0209	.0199	.0187	.0176	.0168	.0158	.0150	.0142	.0134
	.0376	.0359	.0339	.0324	.0306	.0289	.0275	.0250	.0247	.0233
0	.0376	.0398	.0417	.0463	.0441	.0489	.0517	.0541	.0571	.0598
10	.0631	.0660	.0696	.0728	.0768	.0810	.0846	.0892	.0932	.0982
20	.1025	.1080	.1127	.1186	.1248	.1302	.1370	.1429	.1502	.1567
30	.1647	.1716	.1803	.1878	.1955	.2035	.2118	.2203	.2292	.2382
40	.2478	.2576	.2677	.2782	.2891	.3004	.3120	.3240	.3364	.3493
50	.3626	.3764	.3906	.4052	.4203	.4359	.4520	.4586	.4858	.5035
60	.5218	.5407	.5601	.5802	.6009	.6222	.6442	.6669	.6903	.7144
70	.7392	.7648	.7912	.8183	.8462	.8750	.9046	.9352	.9666	.9989
80	1.032	1.066	1.102	1.138	1.175	1.213	1.253	1.293	1.335	1.378
90	1.422	1.467	1.513	1.561	1.610	1.660	1.712	1.765	1.819	1.875
100	1.932	1.991	2.052	2.114	2.178	2.243	2.310	2.379	2.449	2.521
110	2.596	2.672	2.749	2.829	2.911	2.995	3.081	3.169	3.259	3.351
120	3.446	3.543	3.642	3.744	3.848	3.954	4.063	4.174	4.289	4.406
130	4.525	4.647	4.772	4.900	5.031	5.165	5.302	5.442	5.585	5.732
140	5.881	6.034	6.190	6.330	6.513	6.680	6.850	7.024	7.202	7.384
150	7.569	7.759	7.952	8.150	8.351	8.557	8.767	8.981	9.200	9.424
160	9.652	9.885	10.12	10.36	10.61	10.86	11.12	11.38	11.65	11.92
170	12.20	12.48	12.77	13.07	13.37	13.67	13.98	14.30	14.62	14.96
180	15.29	15.63	15.98	16.34	16.70	17.07	17.44	17.82	18.21	18.61
190	19.01	19.42	19.84	20.27	20.70	21.14	21.50	22.05	22.52	22.99
200	23.47	23.96	24.46	24.97	25.48	26.00	26.53	27.07	27.62	28.18
210	28.75	29.33	29.92	30.52	31.13	31.75	32.38	33.02	33.67	34.33
220	35.00	35.68	36.37	37.07	37.78	38.50	39.24	39.99	40.75	41.52
230	42.31	43.11	43.92	44.74	45.57	46.41	47.37	48.14	49.03	49.93
240	50.84	51.76	52.70	53.65	54.62	55.60	56.60	57.61	58.63	59.67
250	60.72	61.79	62.88	63.98	65.10	66.23	67.38	68.54	69.72	70.92
260	72.13	74.36	74.61	75.88	77.17	78.46	79.78	81.11	82.46	83.83
270	85.22	86.63	88.06	89.51	90.97	92.45	93.96	95.49	97.03	98.61
280	100.2	101.8	103.4	105.0	106.7	108.4	110.1	111.8	113.6	115.4
290	117.2	119.0	120.8	122.7	124.6	126.5	128.4	130.4	132.4	134.4
300	136.4	138.5	140.6	142.7	144.8	147.0	149.2	151.4	153.6	155.9
310	158.2	160.5	162.8	165.2	167.6	170.0	172.5	175.0	177.5	180.0
320	182.6	185.2	187.8	190.4	193.1	195.8	198.5	201.3	104.1	206.9
330	209.8	212.7	215.6	218.6	221.6	224.6	227.7	230.8	233.9	237.1
340	240.3	243.5	246.8	250.1	253.4	256.7	260.1	263.6	267.1	270.6
350	274.1	277.7	281.3	284.9	288.6	292.3	296.1	299.9	303.8	307.7
360	311.6	315.5	319.5	323.5	327.6	331.7	335.9	340.1	344.4	348.7
370	353.0	357.4	361.8	366.2	370.7	375.2	379.8	384.4	389.1	393.8
380	398.6	403.4	408.2	413.1	418.1	423.1	428.1	433.1	438.2	443.4
390	448.6	453.9	459.2	464.6	470.0	475.5	481.0	486.2	492.2	497.9
400	503.6	509.3	515.1	521.0	526.9	532.9	538.9	545.0	551.0	557.3

2. Wet bulb-dry bulb moisture determination nomograph technique

Another technique for determining approximate moisture in the flue gas is by the use of a nomograph. Nomographs are mathematically constructed to solve various equations when known process information is supplied. While nomographs may not be as accurate as an actual analysis, they do provide a useful approximate moisture figure. To properly use the nomograph, determine the wet bulb/dry bulb temperatures and proceed with the following steps:

$$\begin{aligned}
 \text{depression} &= t_d - t_w \\
 &= \text{---}^\circ\text{F} - \text{---}^\circ\text{F} \\
 &= \text{---}^\circ\text{F}
 \end{aligned}
 \tag{A-2}$$

On the line from absolute stack gas pressure to wet bulb depression temperature, mark the pivot point on line 1, using Figure A-10.

From the pivot point on line 1 to the  $t_w$ , mark the pivot point on line 2.

From the absolute stack gas pressure through the mark on pivot point on line 2, read % H<sub>2</sub>O on scale B<sub>ws</sub>.

Record this value on the Exercise 3 Hand-in Sheet (page A-22).

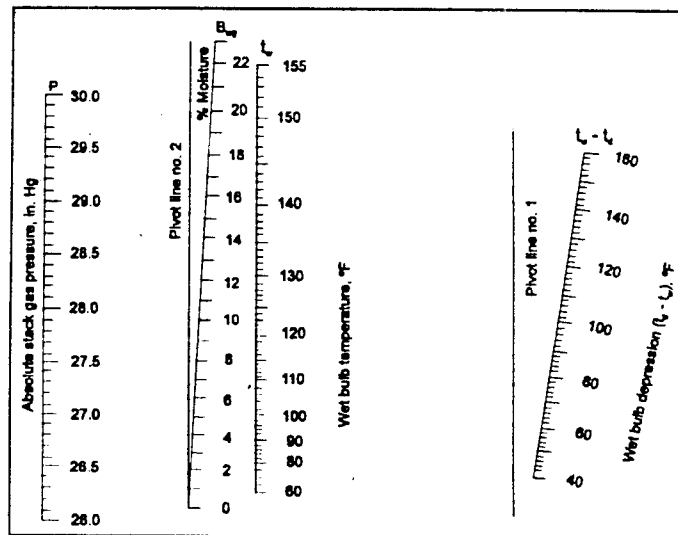

Figure A-10. Nomograph technique: percent moisture in flue gas

3. Wet bulb-dry bulb moisture determination psychrometric chart technique

To use a psychrometric chart, find the dry bulb temperature on the X-axis. Find the wet-bulb temperature on the saturation line (wet bulb temperature line). Draw a line "up" from the dry bulb temperature. Draw a line sideways from the wet bulb temperature. The point of intersection on the two lines is read as the percent water vapor on the Y-axis.

Record this value on the Exercise 3 Hand-in Sheet (page A-22).

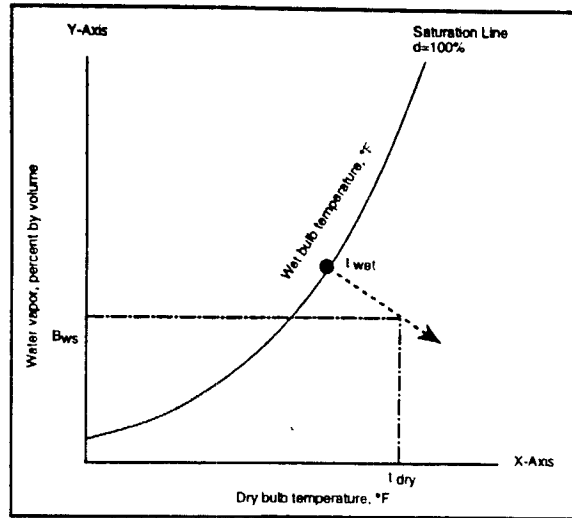

Figure A-11. Using a psychrometric chart

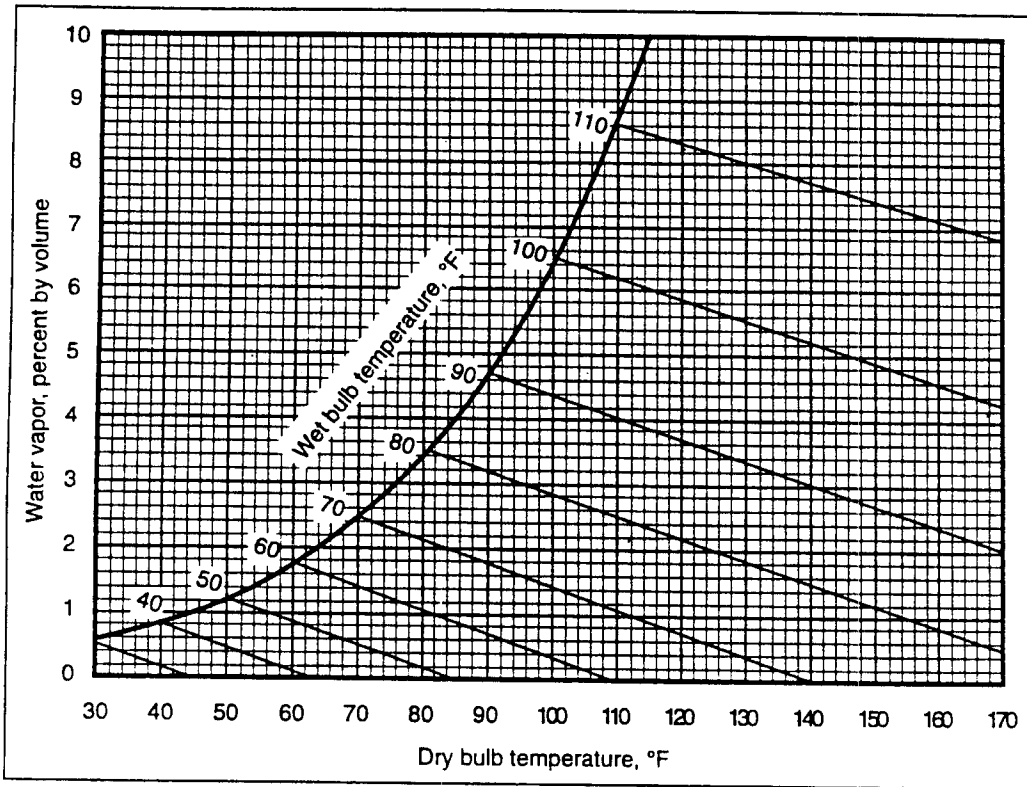

Figure A-12. Psychrometric chart expressing volume of water vapor by percent

Name \_\_\_\_\_

Group No. \_\_\_\_\_

Date \_\_\_\_\_

## Exercise 3 Hand-in Sheet

### Determination of Moisture Content by the Wet Bulb-Dry Bulb Technique

 $t_{\text{dry bulb}}$  \_\_\_\_\_ °F $t_{\text{wet bulb}}$  \_\_\_\_\_ °F $P_{\text{bar}}$  \_\_\_\_\_ in. Hg $P_s$  \_\_\_\_\_ in. H<sub>2</sub>O

1.  $B_{ws}$  \_\_\_\_\_ %      Calculation method
2.  $B_{ws}$  \_\_\_\_\_ %      Nomograph method
3.  $B_{ws}$  \_\_\_\_\_ %      Psychrometric chart method

*Note:* Before turning in this hand-in sheet, record your data on the following duplicate hand-in sheet. Keep the duplicate in your workbook for future reference.



Name \_\_\_\_\_

Group No. \_\_\_\_\_

Date \_\_\_\_\_

### **Exercise 3 Hand-in Sheet**

*(Duplicate: Keep in your workbook for future reference)*

#### **Determination of Moisture Content by the Wet Bulb-Dry Bulb Technique**

 $t_{\text{dry bulb}}$  \_\_\_\_\_ °F $t_{\text{wet bulb}}$  \_\_\_\_\_ °F $P_{\text{bar}}$  \_\_\_\_\_ in. Hg $P_s$  \_\_\_\_\_ in. H<sub>2</sub>O

1.  $B_{ws}$  \_\_\_\_\_ %      Calculation method
2.  $B_{ws}$  \_\_\_\_\_ %      Nomograph method
3.  $B_{ws}$  \_\_\_\_\_ %      Psychrometric chart method

# First Day Laboratory Exercise 4

## Calibration of the Orifice Meter - Determination of the $\Delta H_{@}$

### Laboratory Objective

Upon completion of this laboratory exercise, you should be able to:  
 Calibrate the orifice meter of the Method 5 meter box and obtain a value for the meter box  $\Delta H_{@}$ .

### Introduction

This exercise will be performed on the meter box that your group will be using during the Method 5 test on the third day of the course. Look in the back of your meter box and locate the orifice meter. It should be a metal tube, about 6 in. to 8 in. long and about 0.75 in. diameter and is located after the dry gas meter as shown in Figure A-13.

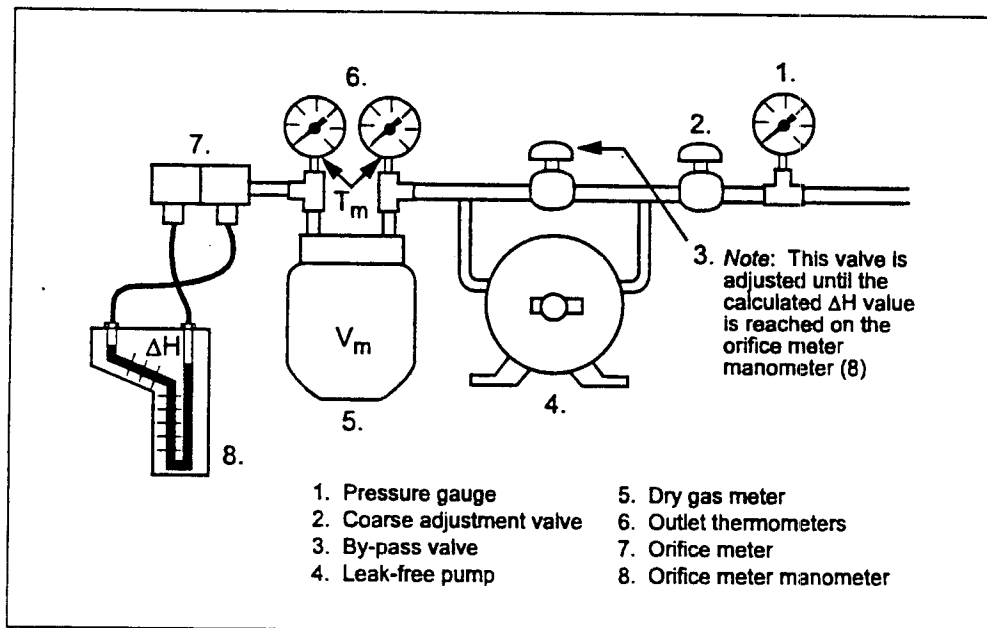

Figure A-13. Major internal components of the meter box

The tube contains a thin flat plate having a sharp-edged hole concentric with the axis of the tube. A pressure differential is created across this orifice plate as gases flow through the orifice. This pressure differential is measured as " $\Delta H$ " using the orifice meter manometer (which is on the face of the meter box).

The flow rate of the gas through the orifice is calculated by the following equation:

$$Q_m = K_m \sqrt{\frac{T_m \Delta H}{P_m M_m}}$$

Where:  $\Delta H$  = pressure differential across the orifice in inches of  $H_2O$  measured by the orifice meter manometer

$K_m$  = the calibration constant for your meter box. This is what you are going to determine.

$Q_m$  = the volumetric flow rate of gas through the orifice meter (and also the dry gas meter) in  $ft^3/min$

$T_m$  = absolute temperature of the meter box (degrees Rankine).

$$T_m = t_m (^{\circ}F) + 460$$

$P_m$  = absolute pressure at the meter (in. Hg)  $P_m = P_{bar} + \Delta H/13.6$

$M_m$  = molecular weight of the gas flowing through the orifice (assume  $M_m = 29.0$  g/g-mole)

## Procedures

Record data in the appropriate spaces on the Exercise 4 Hand-in Sheet (page A-28).

- Step 1. Turn on the meter console.
- Step 2. Close the coarse adjustment valve and turn the by-pass valve all the way counter-clockwise.
- Step 3. Level and zero the orifice meter manometer.
- Step 4. Turn on the pump and partially open the coarse adjustment valve, using it and the by-pass valve to establish an orifice meter manometer reading of  $\Delta H = 0.25$  in.  $H_2O$ .
- Step 5. Read the dry gas meter dial and simultaneously start the stopwatch or mark the time on a watch having a sweep second hand. Allow 2 min to pass, all the while maintaining a  $\Delta H$  of 0.25 in.  $H_2O$  on the manometer using the by-pass valve.
- Step 6. Simultaneously close the coarse adjustment valve and stop the watch (or record the end time).
- Step 7. On the Exercise 4 Hand-in Sheet (page A-28), record the final dry gas meter reading and the temperature of the dry gas meter dial thermometer. (There is a duplicate Exercise Hand-in Sheet that you may keep in your workbook for future reference.)



Step 8. Calculate  $Q_m$  using the following equation:

$$Q_m = \frac{V_f - V_i Y}{\theta}$$

- Where:  $V_f$  = the final volume reading on the dry gas meter (ft<sup>3</sup>)  
 $V_i$  = the initial volume reading on the dry gas meter (ft<sup>3</sup>)  
 $Y$  = the dry gas meter correction factor  
 (should be found somewhere on the meter box)  
 $\theta$  = time elapsed to obtain the volume (about 2 minutes)

Record the result on the Exercise 4 Hand-in Sheet (page A-28).

Step 9. Calculate a value for  $K_m$  using the following expression:

$$K_m = Q_m \sqrt{\frac{P_m M_m}{T_m \Delta H}}$$

- Where:  $K_m$  = the calibration constant for your orifice meter box. This is what you are determining.  
 $Q_m$  = the volumetric flow rate of gas through the orifice meter (and also the dry gas meter) in ft<sup>3</sup>/min. This is what you just measured.  
 $\Delta H$  = pressure differential across the orifice in inches of H<sub>2</sub>O measured by the orifice meter manometer. This is what you set using the by-pass value.  
 $T_m$  = absolute temperature of the meter box (degrees Rankine)  
 $T_m = t_m (^{\circ}\text{F}) + 460.$   
 $P_m$  = absolute pressure at the meter (in. Hg.)  $P_m = P_{\text{bar}} + \Delta H/13.6$   
 $M_m$  = molecular weight of the gas flowing through the orifice (assume  $M_m = 29.0$  g/g-mole for the molecular weight of air)

Step 10. Repeat Steps 4-9, except establish an orifice meter manometer reading of  $\Delta H = 1.0$ .

Step 11. Repeat Steps 4-9, except establish an orifice meter manometer reading of  $\Delta H = 2.0$ .

Step 12. Repeat Steps 4-9, except establish an orifice meter manometer reading of  $\Delta H = 4.0$

Step 13. Repeat Steps 4-9, except establish an orifice meter manometer reading of  $\Delta H = 6.0$ .

Step 14. Average all the values of  $K_m$  and enter the result in the appropriate box on the Exercise 4 Hand-in Sheet (page A-28).

Step 15. Calculate the  $\Delta H_{\text{@}}$  for your meter box.

$\Delta H_{\text{@}}$  is the pressure drop seen across the orifice meter manometer at a flow rate of 0.75 ft/min. under standard EPA conditions for temperature (68°F) and pressure (29.92 in. Hg).

$\Delta H_{\text{@}}$  is obtained by rearranging the orifice meter equation as follows:

$$\Delta H = \frac{Q_m^2 P_m M_m}{\bar{K}_m^2 T_m}$$
$$\Delta H_{\text{@}} = \left( \frac{0.75 \text{ cfm}}{\bar{K}_m} \right)^2 \left( \frac{(29.92 \text{ in. Hg})(29 \text{ g/g-mole})}{528 \text{ }^\circ\text{R}} \right) = \frac{0.9244}{\bar{K}_m^2}$$
$$\Delta H_{\text{@}} = \frac{0.9244}{\bar{K}_m^2}$$



Name \_\_\_\_\_

Group No. \_\_\_\_\_

Date \_\_\_\_\_

## Exercise 4 Hand-in Sheet

### Calibration of the Orifice Meter and Determination of $\Delta H$

1. Determination of  $K_m$

Meter console no. \_\_\_\_\_

DGM No. \_\_\_\_\_

Barometric pressure ( $P_{bar}$ ) \_\_\_\_\_ in. Hg

DGM correction factor (Y) \_\_\_\_\_

Orifice Meter Calibration							
$\Delta H$ in $H_2O$	$V_1$ Initial DGM Dial Reading	$\theta$ Minutes	$V_2$ Final DGM Dial Reading	$t_m$ (°F)	$P_m$ (in. Hg)	$Q_m$ (cfm)	$K_m$
0.25							
0.5							
1.0							
2.0							
4.0							
6.0							
Average ( $\bar{K}_m$ ) =							

2. Determination of  $\Delta H_{\text{@}}$

$$\Delta H_{\text{@}} = \frac{0.9244}{\bar{K}_m^2} = \frac{0.9244}{(\quad)^2} = \quad \text{in. } H_2O$$

*Note:* Before turning in this hand-in sheet, record your data on the following duplicate hand-in sheet. Keep the duplicate in your workbook for future reference.



Name \_\_\_\_\_

Group No. \_\_\_\_\_

Date \_\_\_\_\_

### Exercise 4 Hand-in Sheet

(Duplicate: Keep in your workbook for future reference)

### Calibration of the Orifice Meter and Determination of $\Delta H$

- Determination of  $K_m$

Meter console no. \_\_\_\_\_

DGM No. \_\_\_\_\_

Barometric pressure ( $P_{bar}$ ) \_\_\_\_\_ in. Hg

DGM correction factor (Y) \_\_\_\_\_

Orifice Meter Calibration							
$\Delta H$ in $H_2O$	$V_1$ Initial DGM Dial Reading	$\sigma$ Minutes	$V_2$ Final DGM Dial Reading	$t_m$ ( $^{\circ}F$ )	$P_m$ (in. Hg)	$Q_m$ (cfm)	$K_m$
0.25							
0.5							
1.0							
2.0							
4.0							
6.0							
Average ( $\bar{K}_m$ ) =							

- Determination of  $\Delta H_{\text{e}}$

$$\Delta H_{\text{e}} = \frac{0.9244}{\bar{K}_m^2} = \frac{0.9244}{(\quad)^2} = \quad \text{in. } H_2O$$



Name \_\_\_\_\_

Group No. \_\_\_\_\_

Date \_\_\_\_\_

## Data Hand-in Sheet: First Day Laboratories

### Laboratory Exercise 1

1. Sample location no. \_\_\_\_\_
2. Number of traverse points \_\_\_\_\_  
on a diameter

### Laboratory Exercise 2

1. Pitot tube ID no. \_\_\_\_\_
2. Type S pitot tube  $C_p$  \_\_\_\_\_

### Laboratory Exercise 3

1.  $B_{ws}$  (calculation method) \_\_\_\_\_
2.  $B_{ws}$  (nomograph method) \_\_\_\_\_
3.  $B_{ws}$  (chart method) \_\_\_\_\_
4. Stack temperature ( $T_s$ ) \_\_\_\_\_
5. Stack static pressure ( $P_s$ ) \_\_\_\_\_

### Laboratory Exercise 4

1. Meter console ID no. \_\_\_\_\_
2. Meter temperature ( $T_m$ ) \_\_\_\_\_
3. Orifice meter  $\Delta H_{@}$  \_\_\_\_\_

*Note:* Before turning in this hand-in sheet, record your data on the following duplicate hand-in sheet. Keep the duplicate in your workbook for future reference.





Name \_\_\_\_\_

Group No. \_\_\_\_\_

Date \_\_\_\_\_

## **Data Hand-in Sheet: First Day Laboratories**

*(Duplicate: Keep in your workbook for future reference)*

### Laboratory Exercise 1

1. Sample location no. \_\_\_\_\_
2. Number of traverse points \_\_\_\_\_  
on a diameter

### Laboratory Exercise 2

1. Pitot tube ID no. \_\_\_\_\_
2. Type S pitot tube  $C_p$  \_\_\_\_\_

### Laboratory Exercise 3

1.  $B_{ws}$  (calculation method) \_\_\_\_\_
2.  $B_{ws}$  (nomograph method) \_\_\_\_\_
3.  $B_{ws}$  (chart method) \_\_\_\_\_
4. Stack temperature ( $T_s$ ) \_\_\_\_\_
5. Stack static pressure ( $P_s$ ) \_\_\_\_\_

### Laboratory Exercise 4

1. Meter console ID no. \_\_\_\_\_
2. Meter temperature ( $T_m$ ) \_\_\_\_\_
3. Orifice meter  $\Delta H_{@}$  \_\_\_\_\_



# ***Appendix B***

## ***Second Day Laboratory Exercise***

# ***Second Day Laboratory Exercise***

## ***The Pitot Tube Traverse***

### ***Determination of the Flue Gas Velocity and Volumetric Flow Rate***

#### ***Laboratory Objective***

Upon completion of this laboratory exercise, you will be able to:  
Determine the velocity and volumetric flow rate of the gas in the test duct by performing a pitot tube traverse.

#### ***Introduction***

In this laboratory, you will conduct a pitot tube traverse at the port used by your group in Laboratory Exercise 1 on the first day of the course. Follow the procedures of Method 1, Paragraph 2.3.1.2, "Stacks with Diameters Equal to or Less than 24 In." to locate the sampling points (located in Appendix B of the course manual). Also refer to your work from the First Day Laboratory Exercise 1.

You will conduct a traverse on each of the two diameters to determine the average flue gas velocity. If it is not possible to measure on the vertical diameter with your apparatus, conduct the two traverses on the one horizontal diameter.

#### ***Procedures***

- Step 1. Connect the Type S pitot tube to the pitot tube manometer
- Step 2. Leak-check the pitot tube lines.
- Step 3. Insert the pitot tube into the duct at the farthest point into the duct.
- Step 4. Observe the pitot tube manometer reading and note the value in the table below.
- Step 5. Move the pitot tube to the next point, obtain a manometer reading, and record the result on the following Flue Gas Velocity Data Sheet.
- Step 6. Repeat Step 5 for all of the traverse points on the first diameter.
- Step 7. Move the pitot tube to the port on the second diameter and repeat Steps 4-6 for each traverse point on the diameter. (If this is not possible, repeat Steps 4-6 on the same diameter.)
- Step 8. Complete the following data sheet and perform the appropriate calculations.

Flue Gas Velocity Data Sheet		
Traverse Point	$\Delta p$	$\sqrt{\Delta p}$
1		
2		
3		
4		
5		
6		
7		
8		
9		
10		
11		
12		
13		
14		
15		
16		
17		
18		
19		
20		
21		
22		
23		
24		
	$(\sqrt{\Delta p})_{avg}$	

Step 9. Using the data from both the first day's laboratory exercises and today's laboratory, calculate the flue gas velocity and volumetric flow rate. Complete the Data Hand-in Sheet and turn it in tomorrow morning. (There is a duplicate Data Hand-in Sheet that you may keep in your workbook for future reference.)

## Calculations

### Pitot Tube Equation

$$v_{s(\text{avg})} = K_p C_p (\sqrt{\Delta p})_{\text{avg}} \sqrt{\frac{T_s}{P_s M_s}}$$

Where:  $v_{s(\text{avg})}$  = average velocity of the gas stream, ft/sec

$T_s$  = absolute temperature, °R (°F + 460)

$P_s$  = absolute pressure, in. Hg

$\Delta p$  = velocity pressure, in H<sub>2</sub>O

$K_p$  = constant: 85.49, in units of  $\left( \frac{\text{ft}^2 \text{ in. Hg lbs/lb-mole}}{\text{sec}^2 \text{ in. H}_2\text{O } ^\circ\text{R}} \right)^{1/2}$   
for the above dimensions

$C_p$  = pitot tube coefficient, dimensionless

$M_s$  = the stack gas molecular weight

$$= M_d (1 - B_{ws}) + 18 B_{ws}$$

(Note: Since we are using air in the test duct, use  $M_d = 29.0$ .)

$$v_s = 85.49 \left( \text{in. H}_2\text{O} \right)^{1/2} \left[ \frac{^\circ\text{R}}{\text{in. Hg (lb/lb-mole)}} \right]^{1/2}$$

### Volumetric Flow Rate Equation

There are two equations used for calculating the volumetric flow rate of a flow gas. One determines the flow rate at actual stack temperature and pressure conditions. The other determines the volumetric flow rate corrected to EPA standard conditions of 68° F and 29.92 in. Hg. Both are important.

#### Actual Stack Gas Volumetric Flow Rate

$$Q_a = v_{s(\text{avg})} A_s$$

Stack Gas Volumetric Flow Rate corrected to standard conditions

$$Q_s = 3600 \text{ sec/hr} (1 - B_{ws(avg)}) v_{s(avg)} A \left( \frac{T_{std}}{T_{s(avg)}} \right) \left( \frac{P_s}{P_{std}} \right)$$

- Where:  $Q_u$  = the volumetric flow rate of the gas stream at actual conditions in cubic feet per hour (acfh)
- $Q_s$  = the volumetric flow rate of the gas stream on a dry basis at standard conditions in cubic feet per hour (scfh)
- 3600 = conversion factor (3600 sec/hr)
- $B_{ws(avg)}$  = the average moisture fraction by volume of the gas stream (dimensionless)
- $v_{s(avg)}$  = the average velocity of the gas stream at the sampling site (ft/sec)
- $A_s$  = the cross-sectional area of the gas stream at the sampling site (ft<sup>2</sup>)
- $T_{std}$  = the absolute temperature at standard conditions (528° R)
- $T_{s(avg)}$  = the average, absolute temperature of the gas stream (°R)
- $P_s$  = the average, absolute pressure of the gas stream (in. Hg)
- $P_{std}$  = the absolute pressure at standard conditions (29.92 in. Hg)

$$A = \pi (D/2)^2$$

Where:  $D$  = diameter of the duct

$$A = 3.14 (\text{____ ft}/2)^2$$

$$A = \text{____ ft}^2$$

$$Q_u = 3600 \text{ sec/hr} \text{____ ft/sec} \text{____ ft}^2$$

$$Q_u = \text{____ acfh}$$

$$Q_s = 3600 \text{ sec/hr} (1 - \text{____}) \text{____ ft/sec} \text{____ ft}^2 \frac{\text{____}^\circ\text{R} \text{____ in. Hg}}{\text{____}^\circ\text{R} \text{____ in. Hg}}$$

$$Q_s = \text{____ dscfh}$$

Record the results of these calculations on the following data hand-in sheet.





Name \_\_\_\_\_

Group No. \_\_\_\_\_

Date \_\_\_\_\_

## Data Hand-In Sheet: Second Day Laboratory

### The Pitot Tube Traverse and Determination of the Flue Gas Velocity and Volumetric Flow Rate

Record your data and results of your calculations. Give the units for each entry.

1. No. of traverse points/diameter \_\_\_\_\_
2.  $(\sqrt{\Delta p})_{avg}$  \_\_\_\_\_
3.  $C_p$  \_\_\_\_\_
4.  $T_{s(avg)}$  \_\_\_\_\_
5.  $P_s$  \_\_\_\_\_
6.  $M_s$  \_\_\_\_\_
7.  $v_{s(avg)}$  \_\_\_\_\_
8.  $A$  \_\_\_\_\_
9.  $Q_a$  \_\_\_\_\_
10.  $Q_s$  \_\_\_\_\_

*Note:* Before turning in this hand-in sheet, record your data on the following duplicate hand-in sheet. Keep the duplicate in your workbook for future reference.





Name \_\_\_\_\_

Group No. \_\_\_\_\_

Date \_\_\_\_\_

## Data Hand-In Sheet: Second Day Laboratory

(Duplicate: Keep in your workbook for future reference)

### The Pitot Tube Traverse and Determination of the Flue Gas Velocity and Volumetric Flow Rate

Record your data and results of your calculations. Give the units for each entry.

1. No. of traverse points/diameter \_\_\_\_\_
2.  $(\sqrt{\Delta p})_{avg}$  \_\_\_\_\_
3.  $C_p$  \_\_\_\_\_
4.  $T_{s(avg)}$  \_\_\_\_\_
5.  $P_s$  \_\_\_\_\_
6.  $M_s$  \_\_\_\_\_
7.  $v_{s(avg)}$  \_\_\_\_\_
8.  $A$  \_\_\_\_\_
9.  $Q_a$  \_\_\_\_\_
10.  $Q_s$  \_\_\_\_\_



# ***Appendix C***

## ***Third Day Laboratory Exercise***

# ***Third Day Laboratory Exercise***

## ***The Method 5 Source Test***

### ***Sampling for Particulate Pollutants***

#### ***Laboratory Objective***

Upon completion of this laboratory exercise, you will be able to:  
Determine the mass concentration of particulate matter in the test duct flue gas, by performing Method 5.

#### ***Introduction***

In this laboratory you will conduct a Method 5 source test. Here, you will put together what you have learned in the previous laboratories and lectures. During the test, you will:

1. First set up your isokinetic rate equation. Calculate the K factor for  $\Delta H = K\Delta p$ , assuming the conditions and using the data from the first two laboratories. Check with your instructor for any changes to data (such as a change in barometric pressure or group reassignments).
2. Inspect your partially assembled Method 5 sampling train. Finish assembling the train.
3. Leak-check the train.
4. Perform the test at the traverse points determined previously. If your site location is on a horizontal section of duct, sample the horizontal diameter twice.
5. After the last point is sampled, perform a final leak check and collect your sample. Either weigh your sample or use a value for the particulate weight assigned by your instructor. Determine the moisture collected and the different sampling activities. Work as a group.
6. Perform the source test calculations. Fill in the Data Hand-in sheet (page C-14) and give it to the laboratory instructor before leaving. (There is a duplicate Data Hand-in Sheet that you may keep in your workbook for future reference.)

The Method 5 sampling train is reviewed in Figure C-1, with symbols for parameters associated with different parts of the train. The equation numbers refer to equations used to calculate these source test parameters. The equations are given in Appendix F of this workbook.

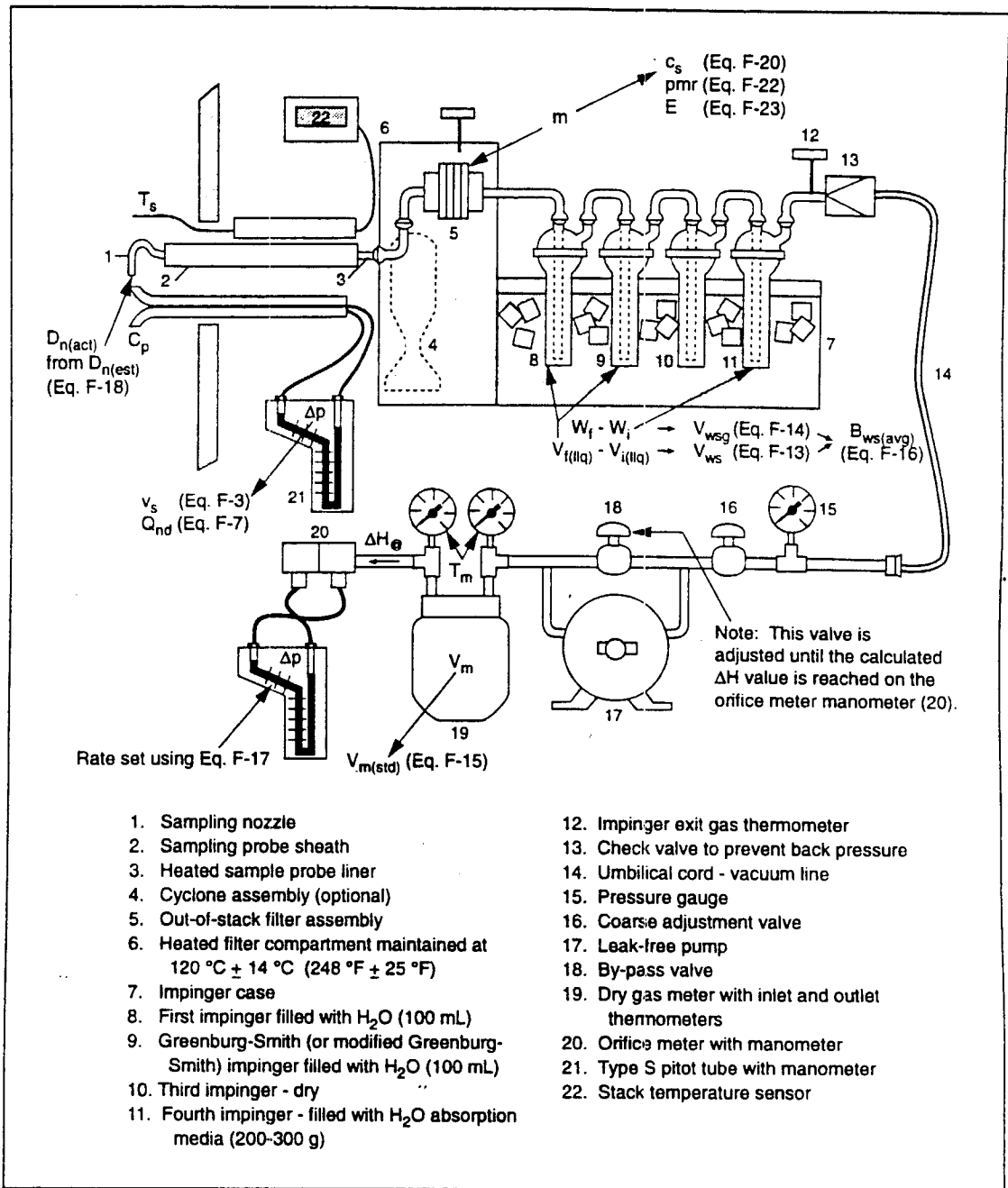

Figure C-1. Method 5 particulate sampling train (with symbols)

A review of the test procedures you will be following is outlined for you in Figure C-2. You have already performed a number of these procedures in the first two laboratories. Check off the ones that you have already done. Check the others off as you proceed through the test.



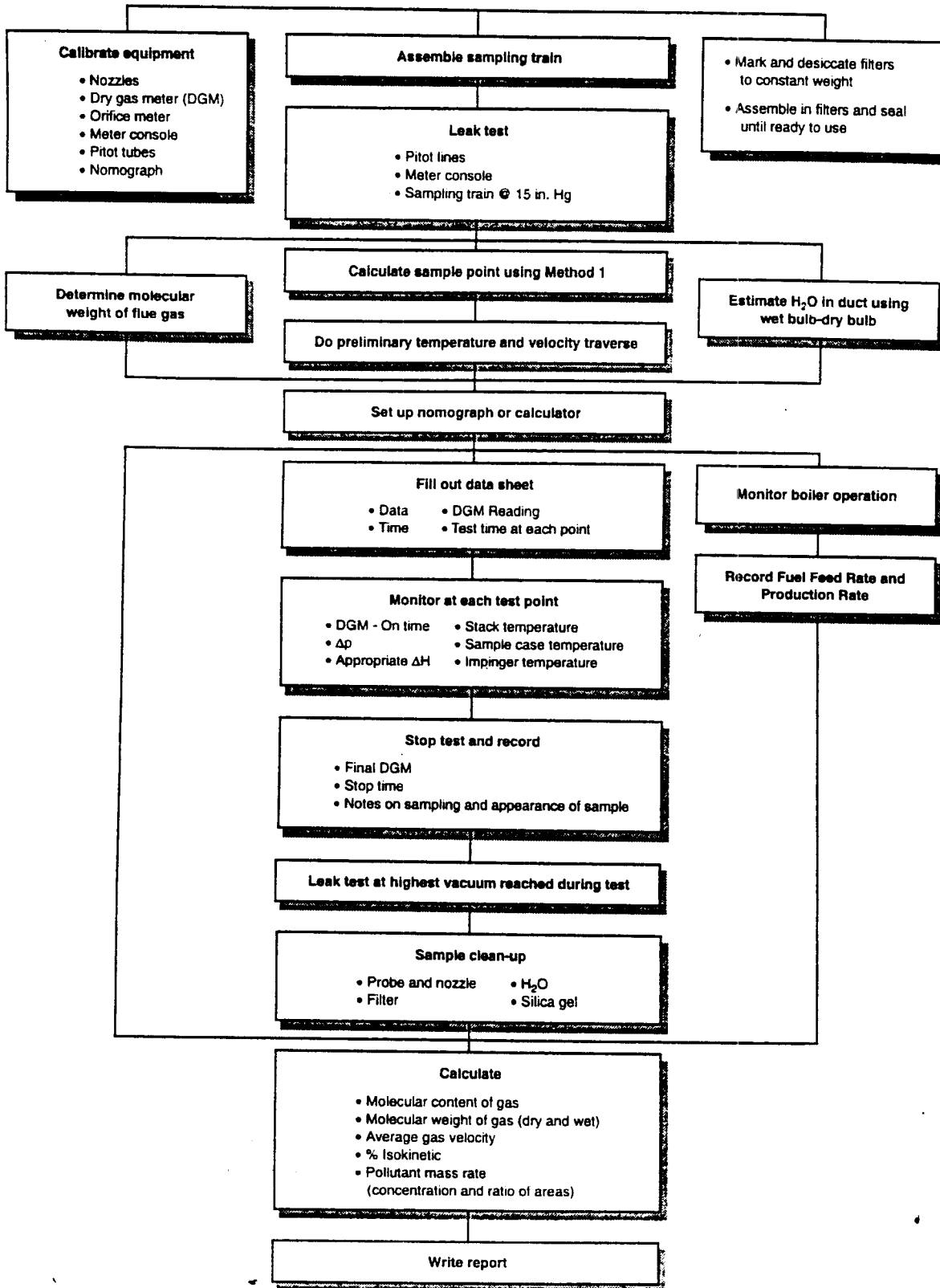

Figure C-2. Source Test Outline

## Procedures:

### A. Setting up the isokinetic rate equation.

- Step 1. Using the data collected during the first and second day laboratories, calculate the nozzle diameter using the following equation:

$$D_{n(est)} = \sqrt{\frac{0.0358 Q_m P_s}{T_m C_p (1 - B_{ws(est)})}} \sqrt{\frac{T_s M_s}{P_s \Delta P_{est}}}$$

- Step 2. Find a nozzle with a diameter closest to that which you have calculated. Alternatively, your instructor may assign a nozzle to you (i.e. you don't have a choice). Measure the actual nozzle diameter and use it in Step 3.
- Step 3. Calculate the K factor of the isokinetic rate equation:

$$\Delta H = \left[ 846.72 D_{n(act)}^4 \Delta H_{@} C_p^2 (1 - B_{ws(est)})^2 \frac{M_d T_m P_s}{M_s T_s P_m} \right] \Delta P$$

Where: [...] = K

- Step 4. Enter all of the data you used to calculate K, into the Particulate Field Data Sheet (page C-10) of this laboratory exercise. Enter the value of the K factor also.

### B. Inspection and assembly of the Method 5 sampling train

- Step 1. Depending on the equipment and time available, the sampling train may or may not be set up. Follow the directions of your instructor.
- Step 2. Inspect the sampling train probe. Check the nozzle to see that it is round. Check the probe and the condition, alignment, and attachment of the pitot tube.
- Step 3. Obtain a pre-weighed filter from your instructor, put it into the filter holder, and assemble into the sampling train.

Make sure that the filter is centered correctly in the holder and that the sample side of the filter will face toward the probe. The filter holder should be tightened until the two halves are secure.

Attach the probe to the filter holder, being sure not to apply excessive torque to the glass components.

- Step 4. Inspect the sample case. Check the thermometer and electrical connections. Check the impingers to see that they are placed in the proper order. The lab instructor will already have filled the impingers (100 mL in the first two, 200 g silica gel in the fourth, the third is left dry.)
- Step 5. Inspect the meter box. Make sure that all connections have been properly made. Turn on the probe and sample case heaters. Adjust the temperatures to those specified by the instructor.

**C. Leak Check**

Step 1. Leak check the train by the following procedure:

- a. Test the completely assembled sampling train at 15 in. on the vacuum gauge.
  - Be certain the valves on the RAC Meter Console are "out."
  - Turn on the console pump
  - Turn on the probe heater and filter box temperature switches, allow to reach operating temperature.
- b. Refer to Figure C-3 and perform the following:

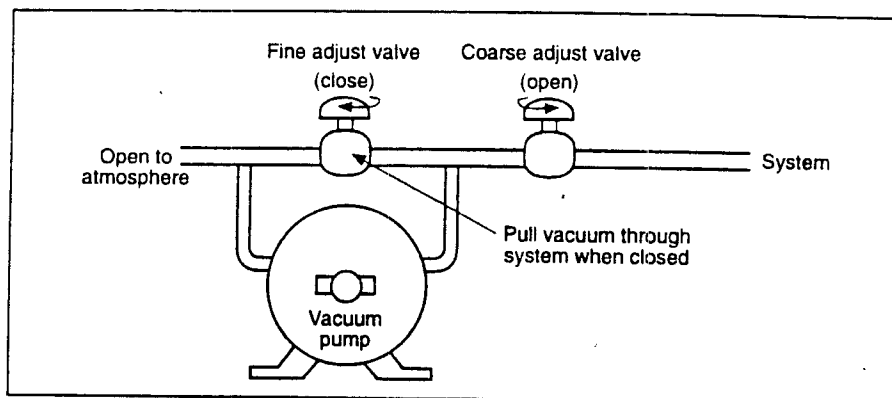

Figure C-3. Valve operation during leak check

- Turn fine adjustment valve fully counter-clockwise.
  - Seal nozzle opening with duct tape or rubber stopper.
  - Open coarse adjust valve slowly until fully counter-clockwise.
  - Slowly turn fine adjust valve clockwise until vacuum reaches 15 in. Hg on the gauge. If you overshoot 15 in. Hg, do not turn fine adjust valve back. Simply read and record at vacuum on gauge.
  - Note DGM dial pointer. If the pointer does not move for 15 sec, the leak test is good. If it continues to move, time the leak using a stopwatch. The maximum acceptable leak rate is 0.02 cfm.
  - Any leak greater than 0.02 cfm must be prevented.
  - Slowly release vacuum at the nozzle before closing coarse adjust valve.
- c. Track down any leaks by successive back-tracking leak checks. Disconnect filter and test the system back from the first impinger, etc.
  - d. Record the leak rate.

**D. Perform the test**

Step. 1. Place ice in the condenser section of the sample box. Make sure that the probe and filter box are at their operating temperature.

- Step 2. Enter the appropriate information on the data sheet. This should include date, time, test time dry gas meter (DGM) reading, and all data used to calculate the K factor of the isokinetic rate equation. Everyone should fill in their own Particulate Field Data Sheet (page C-10) data sheet. Don't assign someone to do all the work.
- Step 3. Move the sampling train to the first traverse point with the nozzle pointing directly into the gas stream. Seal the port and immediately start the pump, noting the time and the DGM reading.
- Determine the  $\Delta p$  reading of the pitot tube from the pitot tube manometer or gauge on the meter box.
  - From the pitot tube reading,  $\Delta p$ , calculate the proper sampling rate,  $\Delta H$ , reading from the isokinetic rate equation.
  - Obtain the proper sampling rate by adjusting the  $\Delta H$  reading of the orifice meter manometer or gauge to the calculated value, using the coarse adjustment and by-pass valves.
  - Test at the traverse point for 2.5 min (or other time period specified by the instructor). When significant changes in stack conditions occur (e.g., the stack temperature changes by more than 25° F, the average temperature of the DGM ( $E_m$ ) varies by more than 11° F, or the moisture content ( $B_{ws}$ ) changes significantly), calculate a new  $\Delta H$  and reset the sampling rate. The time period at each traverse point must be long enough to obtain a total sampling period representative of the process being monitored. The time at each traverse point must be sufficient to obtain a total sample volume of at least 30 dscf.
  - At each traverse point, the following information should be observed and recorded on the Particulate Field Data Sheet (page C-10).
    - Stack temperature ( $t_s$ )
    - Velocity head ( $\Delta p$ )
    - Orifice pressure differential ( $\Delta H$ )
    - Gas temperature at DGM ( $t_m$ )
    - Sample box temperature
    - Condenser temperature
    - Probe temperature
  - Repeat the above steps for each traverse point, sampling 2.5 min at each point (or other time period, as specified). Adjust the sampling rate to correspond to the new  $\Delta p$  reading at each traverse point by adjusting the coarse control and by-pass valves so that the appropriate  $\Delta H$  reading is obtained on the orifice meter manometer. (Obviously, if the  $\Delta p$  reading doesn't change, you don't have to change the sampling rate.)

## E. Final leak check and sample collection

- Step 1. At the completion of the test, close the coarse control valve on the meter box, remove the probe from the stack and turn off the pump. Remove the probe carefully from the stack to ensure that the nozzle does not scrape dust from the inside of the port. Seal the port. Keep the probe elevated to ensure that the sample is not lost. Record all proper information on the Particulate Field Data Sheet (page C-10). This should include final DGM reading, stop time, probe temperature and meter box temperature.
- Step 2. Perform a post leak check on the sample train, following the same procedure as in the pre test leak check. Record the final leak rate on the data sheet.
- Step 3. Sample Recovery. Disassemble the filter holder and remove the filter to a petri dish. Brush any loose particulate matter on to the filter. Seal the probe until it reaches ambient temperature.
- During sample recovery, care must be taken to prevent loss or contamination of the sample.
- Filter holder - Care must be taken when removing the filter from its holder. Be sure that extraneous dirt does not become a part of the sample run. Place the filter into its original container, seal, label, and record the filter number on the Particulate Field Data Sheet (page C-10).
  - Silica gel - Transfer the silica gel from the fourth impinger to its original preweighed container. The use of a funnel to transfer the silica gel would be most helpful. Once it has been transferred, label and seal properly.
  - Condenser - Measure the total volume of condensation ( $\pm 1$  mL) transferring the contents of the first three impingers into a graduated cylinder. Record on the following Particulate Test Calculation Form.
  - Acetone wash-front half - Wash all internal surfaces of the sampling train from the nozzle tip up to the backside of the filter holder with acetone. Determine the volume to the nearest milliliter and transfer to a labeled container. A brush with a handle as long as the probe may be used to dislodge particulate matter from the inside of the probe. Include this with the acetone washings.
- Step 4. Determine the particulate weight. Either weigh the filter to the nearest 0.1 mg or accept a value given by the instructor. Since time may not be available to evaporate the probe catch, accept a value for this particulate weight from the instructor.
- Step 5. Either weigh the silica gel or accept a value from the instructor.

**F. Calculations**

Step 1. Complete the following Particulate Test Calculation Form.

Step 20. Enter the results from your calculations and other requested information into the Data Hand-in Sheet (page C-14) for this laboratory. (There is a duplicate Data Hand-in Sheet that you may keep in your workbook for future reference.)

# Particulate Field Data Sheet

Very important - Fill in all blanks

Plant \_\_\_\_\_ Fyrite no. \_\_\_\_\_ Date rebuilt \_\_\_\_\_ Leak rate @ 15 in. Hg \_\_\_\_\_ Pre-test \_\_\_\_\_  
 Run no. \_\_\_\_\_ Cp \_\_\_\_\_ Test start time \_\_\_\_\_ K \_\_\_\_\_  
 Location \_\_\_\_\_ ΔH<sub>0</sub> \_\_\_\_\_ Stop time \_\_\_\_\_  
 Date \_\_\_\_\_ P<sub>m</sub>, in. Hg \_\_\_\_\_ D<sub>m</sub>, calculated (in.) \_\_\_\_\_  
 Operator \_\_\_\_\_ P<sub>s</sub>, in. Hg \_\_\_\_\_ D<sub>m</sub>, used (in.) \_\_\_\_\_  
 Sample box no. \_\_\_\_\_ B<sub>ws</sub> (assumed) \_\_\_\_\_ Ambient temp., °F \_\_\_\_\_  
 Meter box no. \_\_\_\_\_ M<sub>d</sub> \_\_\_\_\_ Bar. pressure, in. Hg \_\_\_\_\_  
 Nomograph ID no. \_\_\_\_\_ M<sub>s</sub> \_\_\_\_\_ Heater box setting, °F \_\_\_\_\_  
 Filter no. \_\_\_\_\_ T<sub>m</sub>, °R \_\_\_\_\_ Probe heater setting, °F \_\_\_\_\_  
 Orsat no. \_\_\_\_\_ Date rebuilt \_\_\_\_\_ Average ΔH \_\_\_\_\_ Post-test \_\_\_\_\_

Point	Clock time (min)	Dry gas meter C(ft³)	Pitot Δp (in. H <sub>2</sub> O)	Orifice ΔH (in. H <sub>2</sub> O)		Dry gas temp. (°F)		Pump vacuum gauge (in. Hg)	Box temp. (°F)	Impinger temp. (°F)	Stack pressure (in. Hg)	Stack Temp. (°F)	Fyrite %CO <sub>2</sub>
				Desired	Actual	Inlet	Outlet						

Comments: \_\_\_\_\_  
 Test Observers: \_\_\_\_\_

Figure C-4. Particulate field data sheet form

## Method 5 Particulate Test Calculation Form

### A. Necessary Data

1. No. of traverse points \_\_\_\_\_
2. Total test time ( $\theta$ ) \_\_\_\_\_ minutes
3. Water collected silica gel + impinger H<sub>2</sub>O \_\_\_\_\_ mL
4. Particulate weight ( $m_n$ ) \_\_\_\_\_ gm
5. Volume metered  
 $V_m =$  \_\_\_\_\_ ft<sup>3</sup>  $\times Y =$  \_\_\_\_\_ ft<sup>3</sup> (Where Y is the dry gas meter calibration factor)
6. Average  $\Delta p$  \_\_\_\_\_ in. H<sub>2</sub>O
7. Average  $\Delta H$  \_\_\_\_\_ in. H<sub>2</sub>O
8. Average meter temperature  $t_m$  \_\_\_\_\_ °F + 460 = \_\_\_\_\_ °R
9. Average stack temperature  $t_s$  \_\_\_\_\_ °F + 460 = \_\_\_\_\_ °R
10. Stack absolute pressure \_\_\_\_\_ in. Hg
11. Barometric pressure \_\_\_\_\_ in. Hg
12. %CO<sub>2</sub> \_\_\_\_\_; %O<sub>2</sub> \_\_\_\_\_; %CO \_\_\_\_\_; %N<sub>2</sub> \_\_\_\_\_
13. Area of stack \_\_\_\_\_ ft<sup>2</sup>
14. Area of nozzle \_\_\_\_\_ ft<sup>2</sup>

### B. Calculations\*

1. Standard volume metered  
(Y = dry gas meter calibration factor)

$$V_{m(\text{std})} = V_m Y \frac{T_{\text{std}} P_b + \frac{\Delta H}{13.6}}{P_{\text{std}} T_m}$$

$$V_{m(\text{std})} = \text{_____ (ft}^3\text{)} \frac{528 (\text{°R})}{29.92 (\text{in. Hg})} \frac{\text{_____ (in. Hg)} + \frac{\text{_____ (in. H}_2\text{O)}}{13.6 (\text{in. H}_2\text{O/in. Hg})}}{\text{_____ (°R)}} = \text{_____ dscf}$$

*Note:* Fill in the blanks. Units in parentheses are the units for the numbers entered into the blanks. If a number is already filled in, multiply or divide, as appropriate.



## 2. Moisture Content of Stack Gas

H<sub>2</sub>O collected in all impingers in standard cubic feet (scf)

$$V_{wc(std)} = K_1 (V_f - V_i)$$

$$V_{wc(std)} = 0.04707 (\text{ft}^3/\text{mL}) \text{ \_\_\_ (mL) = \_\_\_ (scf)}$$

Moisture Content of Stack Gas ( $B_{ws}$ )

$$B_{ws} = \frac{V_{wc(std)}}{V_{wc(std)} + V_{m(std)}}$$

$$B_{ws} = \frac{\text{\_\_\_ (scf)}}{\text{\_\_\_ (scf)} + \text{\_\_\_ (scf)}} = \text{\_\_\_}$$

Note, if silica gel is used, then use:

$$B_{ws} = \frac{V_{wc(std)} + V_{wsg(std)}}{V_{wc(std)} + V_{wsg(std)} + V_{m(std)}}$$

## C. Molecular Weight of Stack Gas (lb/lb-mole)

1.  $M_d$  (Dry Molecular Weight) =  $\Sigma M_x B_x$

$$M = 0.44 \text{ \_\_\_ \%CO}_2 + 0.32 \text{ \_\_\_ \%O}_2 + 0.28 \text{ \_\_\_ \%CO} + 0.28 \text{ \_\_\_ \%N}_2 = \text{\_\_\_ lb/lb-mole}$$

2.  $M_s$  (Wet Molecular Weight) =  $M_d (1 - B_{ws}) + 18 B_{ws}$

$$M_s (\text{Wet Molecular Weight}) = M_d (1 - B_{ws}) + 18 B_{ws}$$

## 4. Average Stack Gas Velocity

$$\bar{v}_{s(avg)} = K_p C_p \left[ \frac{T_s(avg)}{P_s M_s} \right]^{1/2} [\Delta p]^{1/2}$$

$$\bar{v}_{s(avg)} = 85.48 \left( \text{ft/sec} \left[ \frac{\text{lb/lb-mole (in. Hg)}}{\text{°R (in. H}_2\text{O)}} \right]^{1/2} \right) \left[ \frac{\text{\_\_\_ (°R)}}{\text{\_\_\_ (in. Hg) \_\_\_ (lb/lb-mole)}} \right]^{1/2} [\text{\_\_\_ (in. H}_2\text{O)}]^{1/2}$$

$$\bar{v}_{s(avg)} = \text{\_\_\_ ft/sec}$$

## 5. Average Stack Gas Volumetric Flow Rate

$$Q_s = (3600 \text{ sec/hr}) (v_{s(\text{avg})}) (A_s) (1 - B_{ws(\text{avg})}) \frac{T_{\text{std}} P_s}{T_{s(\text{avg})} P_{\text{std}}}$$

$$Q_s = 3600 (\text{sec/hr}) \text{ \_\_\_ } (\text{ft/sec}) \text{ \_\_\_ } (\text{ft}^2) (1 - \text{ \_\_\_ }) \frac{528 (\text{°R}) \text{ \_\_\_ } (\text{in. Hg})}{\text{ \_\_\_ } (\text{°R}) 29.92 (\text{in. Hg})}$$

$$Q_s = \text{ \_\_\_ } \text{ dscf/hr}$$

## 6. Pollutant Mass Rate

$$\text{pmr} = \left[ \frac{m_n}{V_{m(\text{std})}} \right] \times Q_s$$

$$\text{pmr} = \frac{\text{ \_\_\_ } (\text{g})}{\text{ \_\_\_ } (\text{dscf})} \times \text{ \_\_\_ } (\text{dscf/hr}) \times \frac{1}{454 (\text{g/lb})} = \text{ \_\_\_ } (\text{lb/hr})$$

## 7. Percent Isokinetic Variation (Intermediate Data)

$$\%I = \frac{\text{ \_\_\_ } (\text{°R}) \text{ \_\_\_ } (\text{dscf}) 29.92 (\text{in. Hg})}{\text{ \_\_\_ } (\text{ft}^2) \text{ \_\_\_ } (\text{min}) \text{ \_\_\_ } (\text{ft/sec}) \text{ \_\_\_ } (\text{in. Hg}) 528 (\text{°R}) 60 (\text{sec/min}) (1 - \text{ \_\_\_ })}$$

$$\%I = \text{ \_\_\_ }$$

or

$$\%I = \frac{100 \cdot T_s \left[ K_1 V_{ic} + \left( \frac{V_m Y}{T_m} \right) \left( P_{bar} + \frac{\Delta H}{13.6} \right) \right]}{60 \theta v_s P_s A_s}$$

$$\%I = \frac{100 \text{ \_\_\_ } (\text{°R}) \left[ 0.002669 \left( \frac{\text{in. Hg ft}^3 \text{ °R}}{\text{mL}} \right) \text{ \_\_\_ } (\text{mL}) + \left( \frac{\text{ \_\_\_ } (\text{dscf})}{\text{ \_\_\_ } (\text{°R})} \right) \left( \text{ \_\_\_ } (\text{in. Hg}) + \frac{\text{ \_\_\_ } (\text{in. H}_2\text{O})}{13.6} \right) \right]}{60 \text{ \_\_\_ } (\text{min}) \text{ \_\_\_ } (\text{ft/sec}) \text{ \_\_\_ } (\text{in. Hg}) \text{ \_\_\_ } (\text{ft}^2)}$$





Name \_\_\_\_\_

Group No. \_\_\_\_\_

Date \_\_\_\_\_

## Data Hand-In Sheet: Third Day Laboratory

### Method 5 Source Test Sampling for Particulate Pollutants

- |     |   |                              |
|-----|---|------------------------------|
| 1.  | Port location no.   | _____                        |
| 2.  | Number of sample points                                       | _____                        |
| 3.  | Total test time   | _____ (min)                  |
| 4.  | Duct cross-sectional area ( $A_s$ )                           | _____ (ft <sup>2</sup> )     |
| 5.  | Nozzle area ( $A_n$ )   | _____ (ft <sup>2</sup> )     |
| 6.  | Moisture content ( $B_{ws(avg)}$ )                            | _____ %                      |
| 7.  | Molecular weight of stack gas ( $M_s$ )                       | _____ lb/lb-mole             |
| 8.  | Stack static pressure (abs) ( $P_s$ )                         | _____ in. Hg                 |
| 9.  | Average stack gas temperature $T_{s(avg)}$                    | _____ °R                     |
| 10. | Pitot tube $C_p$  | _____                        |
| 11. | $\Delta H_{@}$  | _____                        |
| 12. | Average $\Delta p$ , $[(\sqrt{\Delta p})_{avg}]^2$            | _____ in. H <sub>2</sub> O   |
| 13. | Average flue gas velocity ( $v_s$ )                           | _____ ft/sec                 |
| 14. | Average stack gas dry standard volumetric flow rate ( $Q_s$ ) | _____ dscfh                  |
| 15. | DGM volume, actual ( $V_m$ )                                  | _____ ft <sup>3</sup>        |
| 16. | DGM volume, standard ( $V_{mstd}$ )                           | _____ dscf                   |
| 17. | Particulate catch weight (m)                                  | _____ mg                     |
| 18. | Particulate matter concentration ( $c_s$ )                    | _____ grains/dscf            |
| 19. | Percent Isokinetic (%I)                                       | _____ %                      |
| 20. | Pollutant mass rate at standard conditions ( $pmr_s$ )        | _____ lb/hr<br>_____ tons/yr |

*Note:* Before turning in this data hand-in sheet, record your data on the following duplicate data hand-in sheet. Keep the duplicate in your workbook for future reference.



Name \_\_\_\_\_

Group No. \_\_\_\_\_

Date \_\_\_\_\_

## Data Hand-In Sheet: Third Day Laboratory

(Duplicate: Keep in your workbook for future reference)

### Method 5 Source Test Sampling for Particulate Pollutants

- |     |   |                                |
|-----|---|--------------------------------|
| 1.  | Port location no.   | _____                          |
| 2.  | Number of sample points                                       | _____                          |
| 3.  | Total test time   | _____ (min)                    |
| 4.  | Duct cross-sectional area ( $A_s$ )                           | _____ ( $\text{ft}^2$ )        |
| 5.  | Nozzle area ( $A_n$ )   | _____ ( $\text{ft}^2$ )        |
| 6.  | Moisture content ( $B_{ws(uvlg)}$ )                           | _____ %                        |
| 7.  | Molecular weight of stack gas ( $M_s$ )                       | _____ lb/lb-mole               |
| 8.  | Stack static pressure (abs) ( $P_s$ )                         | _____ in. Hg                   |
| 9.  | Average stack gas temperature $T_{s(uvlg)}$                   | _____ °R                       |
| 10. | Pitot tube $C_p$  | _____                          |
| 11. | $\Delta H_{@}$  | _____                          |
| 12. | Average $\Delta p$ , $[(\sqrt{\Delta p})_{avg}]^2$            | _____ in. $\text{H}_2\text{O}$ |
| 13. | Average flue gas velocity ( $v_s$ )                           | _____ ft/sec                   |
| 14. | Average stack gas dry standard volumetric flow rate ( $Q_s$ ) | _____ dscfh                    |
| 15. | DGM volume, actual ( $V_m$ )                                  | _____ $\text{ft}^3$            |
| 16. | DGM volume, standard ( $V_{mstd}$ )                           | _____ dscf                     |
| 17. | Particulate catch weight (m)                                  | _____ mg                       |
| 18. | Particulate matter concentration ( $c_s$ )                    | _____ grains/dscf              |
| 19. | Percent Isokinetic (%I)                                       | _____ %                        |
| 20. | Pollutant mass rate at standard conditions ( $\text{pmr}_s$ ) | _____ lb/hr                    |
|     |   | _____ tons/yr                  |



# ***Appendix D***

## ***Homework Problems***



## Problem Set 1

1. If an ideal gas has a volume of 20 ft<sup>3</sup> at 235° F and 29.91 in. Hg, what will its volume be at 68° F and 29.80 in. Hg?
2. If 20 L of gas contained in a balloon under a pressure of 29.92 in. Hg are moved to a location where the atmospheric pressure is 26.5 in. Hg, what will its new volume be? (Assume constant temperature)
3. How many moles are in the following:
  - a. 1.6 lb of oxygen
  - b. In 35 cc of water?
4. The  $\Delta p$  across a pitot tube manometer is 1.5 in. H<sub>2</sub>O, the stack temperature is 286° F, the stack static pressure is +1.2 in. H<sub>2</sub>O, the barometric pressure is 29.86 in. Hg, and the stack gas molecular weight is 30 lb/lb-mole. What is the flue gas velocity if the pitot tube has a  $C_p$  of:
  - a. 0.81
  - b. 0.84
5. If a Method 5 source test determined that a particulate concentration was 0.70 grains/dscf what would be the pollutant mass rate in tons/year? Use the velocity calculated in Problem 4(a) and assume that the velocity traverse was conducted on a 15 ft diameter. Assume  $B_{ws} = 12\%$ .

Name \_\_\_\_\_  
Group No. \_\_\_\_\_  
Date \_\_\_\_\_

## Problem Set 1: Hand-in Sheet

1. \_\_\_\_\_  $\text{ft}^3$
2. \_\_\_\_\_ L
3. a. \_\_\_\_\_  
b. \_\_\_\_\_
4. a. \_\_\_\_\_  $\text{ft}/\text{sec}$   
b. \_\_\_\_\_  $\text{ft}/\text{sec}$
5. \_\_\_\_\_  $\text{ton}/\text{yr}$

*Note:* Before turning in this hand-in sheet, record your data on the following duplicate problem set 1: hand-in sheet. Keep the duplicate in your workbook for future reference.



Name \_\_\_\_\_  
Group No. \_\_\_\_\_  
Date \_\_\_\_\_

## Problem Set 1: Hand-in Sheet

*(Duplicate: Keep in your workbook for future reference)*

1. \_\_\_\_\_  $\text{ft}^3$
2. \_\_\_\_\_ L
3. a. \_\_\_\_\_  
b. \_\_\_\_\_
4. a. \_\_\_\_\_  $\text{ft}/\text{sec}$   
b. \_\_\_\_\_  $\text{ft}/\text{sec}$
5. \_\_\_\_\_  $\text{ton}/\text{yr}$

## Problem Set 2

- Given the following pre-test information, estimate the nozzle diameter required to sample at a rate of 0.75 cfm.

$\Delta H_{\text{e}} = 1.24$	$B_{\text{ws}} = 0.112$
$C_p = 0.79$	$t_s = 310 \text{ }^\circ\text{F}$
$t_m = 80 \text{ }^\circ\text{F}$	$M_d = 30.1 \text{ lb/lb-mole}$
$P_m = 29.93 \text{ in. Hg}$	$\Delta p_{\text{avg}} = 1.5 \text{ in. H}_2\text{O}$
$p_s = -1.1 \text{ in. H}_2\text{O}$	
$P_{\text{bar}} = 29.92 \text{ in. Hg}$	

- You have in your toolbox nozzles with diameters of 0.130, .261, .380, and .523 in. Choose one and calculate the K factor for the isokinetic rate equation.
- From the result of Problem 2, and using the sampling pump by-pass valve, if you wanted to sample isokinetically, to what orifice meter manometer reading would you adjust the value if the pitot manometer reading was observed to be 1.2 in H<sub>2</sub>O?
- In Problem 3, to what  $\Delta H$  value would you adjust the system to if  $\Delta p_{\text{avg}} = 0.86 \text{ in. H}_2\text{O}$ ? If  $\Delta p_{\text{avg}} = 1.0 \text{ in. H}_2\text{O}$ ?
- Figure D-1 represents a duct to be sampled using the Method 5 sampling train. Using Method 1 guidelines, calculate the equivalent diameter of the duct, select the best sampling site, sample port entry number, and sampling point number. (The plant will weld on threaded 3 in. diameter, 6 in. long steel pipe nipples at sample ports.)

Sketch out all work with dimensions.

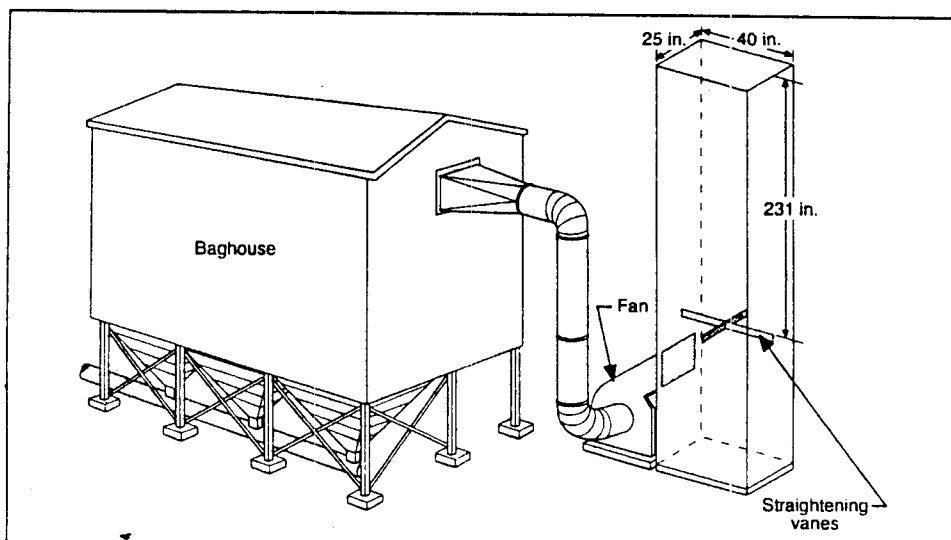

Figure D-1. Sampling site

6. Using an Orsat apparatus, a source test team found that a bituminous coal-fired power plant had  $\%O_2 = 8.0$  and  $\%CO_2 = 9.1\%$ . Do you think the test was good or bad? Why?

7. **Molecular Weight of a Stack Gas**

An integrated bag sample of the stack gas in a coal-fired power plant duct was analyzed by Orsat. The Orsat indicated readings of 14.2 for  $CO_2$ , 21.4 for  $O_2$ , and 21.4 for  $CO$ . The moisture content of the stack gas was 7%  $H_2O$  vapor. What is the:

- dry molecular weights of the gas
- wet molecular weights of the gas

Stack Gas Constituents

$$CO_2 = 14.2\% \text{ by volume}$$

$$O_2 = 21.4 - 14.2 = 7.2\% \text{ by volume}$$

$$CO = 21.4 - 21.4 = 0\%$$

$$N_2 = 100 - 21.4 = 78.6\% \text{ by volume}$$

$$H_2O = 7\%$$

8. A dry gas meter indicated that  $32 \text{ ft}^3$  of gas passed through the meter during a source test. What would the volume of gas have been at stack conditions if the moisture content of the stack gas was 12% and its temperature was  $198^\circ \text{ F}$ ? (Estimate any other parameters that you might need in the solution of this problem.)



Name \_\_\_\_\_  
Group No. \_\_\_\_\_  
Date \_\_\_\_\_

## Problem Set 2: Hand-in Sheet

1. \_\_\_\_\_ in.
2. \_\_\_\_\_
3. \_\_\_\_\_ in. H<sub>2</sub>O
4. \_\_\_\_\_ in. H<sub>2</sub>O
5. \_\_\_\_\_
  
6. \_\_\_\_\_
  
7. a. \_\_\_\_\_ lb/lb-mole dry  
b. \_\_\_\_\_ lb/lb-mole wet
8. \_\_\_\_\_ ft<sup>3</sup>

*Note:* Before turning in this hand-in sheet, record your data on the following duplicate hand-in sheet. Keep the duplicate in your workbook for future reference.





Name \_\_\_\_\_  
Group No. \_\_\_\_\_  
Date \_\_\_\_\_

**Problem Set 2: Hand-in Sheet**  
(Duplicate: Keep in your workbook for future reference)

1. \_\_\_\_\_ in.
2. \_\_\_\_\_
3. \_\_\_\_\_ in. H<sub>2</sub>O
4. \_\_\_\_\_ in. H<sub>2</sub>O
5. \_\_\_\_\_
  
6. \_\_\_\_\_
  
7. a. \_\_\_\_\_ lb/lb-mole dry  
b. \_\_\_\_\_ lb/lb-mole wet
8. \_\_\_\_\_ ft<sup>3</sup>

## Problem Set 3

1. A 60-minute stack test gave intermediate data as follows:

% H<sub>2</sub>O in stack gas = 6.5

Volume metered at standard conditions = 38.8 dscf

Static pressure in the stack = 0.25 in. H<sub>2</sub>O

Barometric pressure = 30.30 in. Hg

Nozzle diameter = 0.248 in.

Average velocity = 49.8 ft/sec

Average stack temperature = 296° F

What is the percent isokinetic for this source test?

2. How would your result in Problem 1 change if you found after the test that your estimation of the moisture content was incorrect and that the actual value of  $B_{ws}$  is 0.073?
3. Percent Isokinetic

A 60-minute source test conducted at an oil-fired steam generation facility provided the following information:

Average stack temperature = 300° F

Average stack gas velocity = 50.0 ft/sec

Volume sampled at meter conditions = 40 ft<sup>3</sup>

Average temperature at the meter = 70° F

Static pressure in the stack = +0.2 in. H<sub>2</sub>O

Barometric pressure = 30.26 in. Hg

Average pressure differential across the orifice = 1.5 in. H<sub>2</sub>O

*Note:*  $V_m = \text{Volume at meter} \times \text{Dry Gas Meter Correction Factor (DGMCF)}$

In this example, assume DGMCF = 1

H<sub>2</sub>O collected in the impingers = 100 mL

Sampling nozzle diameter = 0.250 in.

What is the percent isokinetic for this source test?

## 4. Moisture Content of a Stack Gas

Method 4 for determination of the moisture content of a stack gas was completed at a coal-fired power plant duct. From the following data, calculate the %H<sub>2</sub>O present in the stack gas.

$$V_{\text{metered}} = 1.258 \text{ cf}$$

$$\text{Test time} = 20 \text{ minutes}$$

$$t_s = 250^\circ\text{F}$$

$$t_m = 80^\circ\text{F}$$

$$P_m = 30.25 \text{ in. Hg}$$

$$\text{H}_2\text{O volume collected in the impingers} = 2.6 \text{ mL}$$

$$\text{H}_2\text{O weight increase in Silica Gel} = 2.4 \text{ gm}$$

$$Y = 1.0$$



Name \_\_\_\_\_  
Group No. \_\_\_\_\_  
Date \_\_\_\_\_

### ***Problem Set 3: Hand-in Sheet***

1. \_\_\_\_\_ %I
2. \_\_\_\_\_ %I
3. \_\_\_\_\_ %I
4. \_\_\_\_\_ H<sub>2</sub>O

*Note:* Before turning in this hand-in sheet, record your data on the following duplicate hand-in sheet. Keep the duplicate in your workbook for future reference.



Name \_\_\_\_\_  
Group No. \_\_\_\_\_  
Date \_\_\_\_\_

### **Problem Set 3: Hand-in Sheet**

*(Duplicate: Keep in your workbook for future reference)*

1. \_\_\_\_\_ %I
2. \_\_\_\_\_ %I
3. \_\_\_\_\_ %I
4. \_\_\_\_\_ H<sub>2</sub>O



## ***Problem Set Worksheets***

---

## ***Problem Set Worksheets***

## ***Problem Set Worksheets***

# ***Appendix E***

## ***Symbols***

## ***Symbols Used for Variables in Methods 2 - 5***

The following pages summarize subscripts, symbols, and associated units used in the field and report programs of this course. Particular attention should be paid to the units associated with each symbol. In the source testing reference methods, the calculations are generally designed so that the variables are expressed in those units actually measured. For example, if barometric pressure is measured in inches of mercury, that value will be substituted into the equations (not one converted to atmospheres, pascals, or millimeters of mercury).

### ***Subscripts***

act	actual
atm	atmospheric
avg	average
bar	barometric
corr	corrected
d or dry	dry basis
est	estimated
f or final	final
i	interval number ( $i^{\text{th}}$ interval)
i	initial
int	intermediate
liq	liquid
m	at meter
n	at nozzle
p	of pitot tube
s	at stack
std	standard conditions
tot	total
wc	water vapor condensed
ws	wet-stack basis
wsg	water collected on silica gel

### ***Symbols and Units***

The symbols for volume are as follows. Metric equivalents are given in parentheses.

dcf	dry cubic foot
dcm	dry cubic meter
dscf	dry standard cubic foot
dscm	dry standard cubic meter
mL	milliliter (for liquid measure)

$A_n$	cross-sectional area of nozzle, $\text{ft}^2$ ( $\text{m}^2$ ) <sup>a</sup>
$A_s$	cross-sectional area of stack, $\text{ft}^2$ ( $\text{m}^2$ )
$B_{ws(\text{avg})}$	average fraction of water vapor in gas stream (dimensionless), used in report program
$B_{ws(\text{est})}$	estimated fraction of water vapor in gas stream (dimensionless), used in field program
$C_p$	pitot tube calibration coefficient (dimensionless)
$c_s$	concentration of particulate matter in stack gas, mass per volume, on a dry basis, corrected to standard conditions, $\text{lb/dscf}$ ( $\text{g/dscm}$ )
$D_n$	diameter of nozzle, in. (cm)
$D_{n(\text{act})}$	actual diameter of nozzle used in test (chosen closest to estimated value), in. (cm)
$D_{n(\text{est})}$	estimated diameter of nozzle obtained from presurvey data, in. (cm)
$E$	emission rate, mass per heat input, $\text{lb}/10^6$ Btu ( $\text{ng}/\text{J}$ )
$F_d$	F factor with $c_s$ and $\text{O}_2$ on a dry basis, used to calculate particulate emission levels in terms of the standard expressed as $\text{lb}/10^6$ Btu ( $\text{ng}/\text{J}$ ), units of $\text{dscf}/10^6$ Btu ( $\text{dscm}/\text{J}$ )
$F_o$	F factor for checking Orsat data (dimensionless)
$K$	symbol for combination of mathematical terms used in isokinetic rate equation (dimensionless), known as the K factor
$K_p$	pitot tube constant, 85.49 $\text{ft}/\text{sec}$ (34.97 $\text{m}/\text{s}$ )
$K_1$	Method 4 factor for calculating $V_{wc(\text{std})}$ , 0.04707 $\text{ft}^3/\text{mL}$ (0.001333 $\text{m}^3/\text{mL}$ )
$K_2$	Method 4 factor for calculating $V_{wsg(\text{std})}$ , 0.04715 $\text{ft}^3/\text{g}$ (0.001335 $\text{m}^3/\text{g}$ )
$K_3$	Method 5 factor for calculating isokinetic variation from raw data, 0.002669 in. $\text{Hg}\text{-ft}^3/\text{mL}\text{-}^\circ\text{R}$ (0.003454 $\text{mm Hg}\text{-m}^3/\text{mL}\text{-}^\circ\text{K}$ )
$K_4$	Method 5 factor for calculating isokinetic variation from intermediate data, 0.09450 in. $\text{Hg}/^\circ\text{R}$ (4.320 $\text{mm Hg}/^\circ\text{K}$ )
$m$	mass of particulate matter collected, mg
$M_d$	molecular weight of stack gas, dry basis, $\text{lb}/\text{lb}\text{-mole}$ ( $\text{g}/\text{g}\text{-mol}$ )
$M_s$	molecular weight of stack gas, wet basis, $\text{lb}/\text{lb}\text{-mole}$ ( $\text{g}/\text{g}\text{-mol}$ )
%EA	percentage of excess air
%CO	percentage of carbon monoxide by volume, dry basis
%CO <sub>2</sub>	percentage of carbon dioxide by volume, dry basis
%N <sub>2</sub>	percentage of nitrogen by volume, dry basis
%O <sub>2</sub>	percentage of oxygen by volume, dry basis
%I	ratio of the velocity of stack gas in the sampling nozzle to the velocity of approaching gas stream times 100; the percent isokinetic
%I <sub>final</sub>	percent isokinetic calculated using final test data
%I <sub>int</sub>	percent isokinetic calculated using pretest or field data
pmr	pollutant mass rate, mass per time, $\text{lb}/\text{hr}$ ( $\text{kg}/\text{h}$ )
$P_{\text{bar}}$	barometric pressure at measurement site, in. Hg (mmHg)

$P_m$	absolute pressure at the meter, $P_{bar} + (\Delta H/13.6)$ , in. Hg (mmHg)
$P_s$	measured static pressure in stack, in. H <sub>2</sub> O (mm H <sub>2</sub> O)
$P_s$	absolute static pressure in stack, $P_{bar} + (p_s/13.6)$ , in. Hg (mmHg)
$P_{std}$	standard absolute pressure, 29.92 in. Hg (760 mmHg)
$Q_m$	volumetric flow rate at the meter, dcf/min (m <sup>3</sup> /min)
$Q_{std}$	volumetric flow rate of dry stack gas, corrected to standard conditions, dscf/hr (dscm/h), used in field program
$Q_{std(avg)}$	average standard volumetric flow rate, dscf/hr (dscm/h), used in report program
$t_m$	temperature at the meter, °F (°C)
$t_{m(avg)}$	average temperature of meter over test period, °F (°C), used in report program
$T_m$	absolute temperature at the meter, 460 °R + $t_m$ (273 K + $t_m$ )
$T_{m(avg)}$	average absolute temperature of meter over test period, °R (°K), used in report program
$t_s$	temperature of the stack, °F (°C), used in field program
$t_{s(avg)}$	average temperature of stack gas over test period, °F (°C), used in report program
$T_s$	absolute temperature of the stack, 460 °R + $t_s$ (273 °K + $t_s$ ), calculated in field program
$T_{s(avg)}$	average absolute temperature of stack gas over test period, °R (°K), used in report program
$T_{std}$	standard absolute temperature, 528 °R (293 °K)
$V_{f(liq)}$	final volume of liquid in condenser (impingers), mL
$V_{i(liq)}$	initial volume, if any, of liquid in condenser, mL
$V_{lc}$	volume of liquid collected in impingers, mL
$V_m$	dry gas volume measured by dry gas meter at actual conditions for each test point, $V_{f(dry)} - V_{i(dry)}$ , dcf (dcm)
$V_{m(std)}$	dry gas volume measured by dry gas meter, corrected to standard conditions, dscf (dscm)
$V_{m(tot)}$	total dry gas volume measured at meter for entire test, dcf (dcm), used in report program
$V_{wc(std)}$	volume of water vapor condensed, corrected to standard conditions, $K_1 (V_{f(liq)} - V_{i(liq)})$ , scf (scm)
$V_{wgc(std)}$	volume of water vapor collected on silica gel, corrected to standard conditions, $K_2 (W_f - W_i)$ , scf (scm)
$v_s$	stack gas velocity, ft/sec (m/s), used in field program
$v_{s(avg)}$	average stack gas velocity, ft/sec (m/s), used in report program
$W_f$	final weight of silica gel, or silica gel plus impinger, g
$W_i$	initial weight of silica gel, or silica gel plus impinger, g
$Y$	correction factor for dry gas meter (dimensionless)
$\Delta H$	average pressure differential across the orifice meter, in. H <sub>2</sub> O (mm H <sub>2</sub> O)

$\Delta H_{\text{e}}$	calibration expression for the orifice meter, pressure drop across the orifice meter for air at standard conditions and a flow rate, $Q_m$ , of 0.75 dscf/min (0.0212 dscm/min)
$\Delta p_{\text{(act)}}$	pressure drop across the pitot tube manometer as actually read at a traverse point, in. H <sub>2</sub> O (mm H <sub>2</sub> O)
$\Delta p_{\text{avg}}$	average pressure drop across the pitot tube manometer during the test, to be used in the pitot tube equation for calculating $v_{s(\text{avg})}$ , equal to $[(\sqrt{\Delta p})_{\text{avg}}]^2$ , ft/sec (m/s)
$(\sqrt{\Delta p})_{\text{avg}}$	average of the square roots of the pitot tube manometer pressure drop readings, equal to, where $n$ = number of $\Delta p_i$ s, (ft/sec) <sup>1/2</sup> , (m/s) <sup>1/2</sup>
	$\frac{\sum_{i=1}^n \sqrt{\Delta p_i}}{n}$
$\Delta p_{\text{est}}$	estimate of pitot tube manometer pressure drop value used to estimate nozzle size, in. H <sub>2</sub> O (mm H <sub>2</sub> O)
$\Delta p_i$	pitot tube manometer pressure drop reading during test interval, $i$ , in. H <sub>2</sub> O (mm H <sub>2</sub> O)
$q$	total sampling time, min
$q_i$	sampling time between test readings, min
$2.205 \times 10^{-6}$	fraction of a pound in a milligram, lb/mg
0.264	ratio of O <sub>2</sub> to N <sub>2</sub> in air, V/V (dimensionless)
0.280	molecular weight of N <sub>2</sub> or CO divided by 100, lb/lb-mole (g/g-mol)
0.320	molecular weight of O <sub>2</sub> divided by 100, lb/lb-mole (g/g-mol)
0.440	molecular weight of CO <sub>2</sub> divided by 100, lb/lb-mole (g/g-mol)
13.6	specific gravity of mercury, in. H <sub>2</sub> O/in. Hg
17.32	units constant used in %I <sub>int</sub> equation, $\left(\frac{\text{in.}^2}{\text{ft}^2}\right)\left(\frac{\text{min}}{\text{sec}}\right)\left(\frac{\text{°R}}{\text{in. Hg}}\right)$
17.64	$T_{\text{std}}/P_{\text{std}}$ , °F/in. Hg
18.0	molecular weight of water, lb/lb-mole (g/g-mol)
20.9	percentage of O <sub>2</sub> in air
60	number of seconds in a minute, sec/min
183.35	constant for $A_n$ , to be used in %I <sub>final</sub> equation, in. <sup>2</sup> /ft <sup>2</sup>
3600	number of seconds in an hour, sec/hr





# ***Appendix F***

## ***Equations Summary***

# Source-Sampling Equations for EPA Methods 2 - 5

## Method 2

Table F-1. Method 2: Gas Velocity and Volumetric Flow Rate			
	Calculations	Units	Program
(Eq. F-1) Average of the square roots of $\Delta p_i$ s	$(\sqrt{\Delta p})_{avg} = \frac{\sum \sqrt{\Delta p_i}}{n}$	(in. H <sub>2</sub> O) <sup>1/2</sup>	Report
(Eq. F-2) Average $\Delta p$	$\Delta p_{avg} = [(\sqrt{\Delta p})_{avg}]^2$	in. H <sub>2</sub> O	Report
(Eq. F-3) Stack gas velocity during test interval, $i$	$v_i = K_p C_p \sqrt{\frac{T_i \Delta p_i}{P_i M_i}}$	ft/sec	Field
(Eq. F-4) Average stack gas velocity over test period		ft/sec	Report
(Eq. F-5)	$v_{i(avg)} = K_p C_p (\sqrt{\Delta p})_{avg} \sqrt{\frac{T_{i(avg)}}{P_i M_i}}$	ft/sec	Report
(Eq. F-6) Standard volumetric flow rate of dry stack gas during test interval, $i$	$Q_{std} = 3600 (1 - B_{wi}) v_i A_i \left( \frac{T_{std}}{T_{i(avg)}} \right) \left( \frac{P_i}{P_{std}} \right)$		
(Eq. F-7) Average standard flow rate of dry stack gas over test period	$Q_{std(avg)} = 3600 (1 - B_{ws(avg)}) v_{i(avg)} A_i \left( \frac{T_{std}}{T_{i(avg)}} \right) \left( \frac{P_i}{P_{std}} \right)$	ft <sup>3</sup> /min	Report
(Eq. F-8) % Nitrogen	$\% N_2 = 100 - \% CO_2 - \% O_2 - \% CO$	Percent (dimensionless)	Report
(Eq. F-9) Molecular weight of stack gas, dry basis	$M_d = 0.44 (\% CO_2) + 0.32 (\% O_2) + 0.28 (\% N_2 + \% CO)$	lb/lb-mole	Report
(Eq. F-10) Molecular weight of stack gas, wet basis	$M_i = M_d (1 - B_{wi}) + 18 B_{wi}$	lb/lb-mole	Field and Report
(Eq. F-11) % Excess air	$\% EA = \frac{-(\% O_2) + 0.5 (\% CO)}{0.264 (\% N_2) - (\% O_2) + 0.5 (\% CO)} \times 100$	Percent (dimensionless)	Report
(Eq. F-12) $F_o$ factor	$F_o = \frac{20.9 - \% O_2}{\% CO_2}$	Dimensionless	Report

## Method 4

Table F-2. Method 4: Moisture Content of Stack Gas			
	Calculations	Units	Program
(Eq. F-13) Volume of water condensed	$V_{wc} = K_1 (V_{i(lq)} - V_{i(lq)})$	scf	Report
(Eq. F-14) Volume of water vapor collected on silica gel	$V_{wv(std)} = K_2 (W_f - W_i)$	scf	Report
(Eq. F-15) Gas volume at standard conditions	Where: $K_1 = 0.04707 \text{ ft}^3/\text{mL}$ $K_2 = 0.04715 \text{ ft}^3/\text{g}$		
(Eq. F-16) Average moisture content	$V_{m(std)} = V_m Y \left( \frac{T_{std}}{P_{std}} \right) \left( \frac{P_{bar} + \frac{\Delta H}{13.6}}{T_m} \right)$ $B_{ws(avg)} = \frac{V_{wc(std)} + V_{wv(std)}}{V_{wc(std)} + V_{wv(std)} + V_{m(std)}}$	dscf  fraction (dimensionless)	Report  Report

## Method 5

Table F-3. Method 5: Field Calculations			
	Calculations	Units	Program
(Eq. F-17) Isokinetic ( $\Delta H$ ) rate	$\Delta H = \left[ 846.872 D_n^4 (\text{act}) \Delta H_w C_p^2 (1 - B_{ws(\text{act})})^2 \frac{M_d T_m P_s}{M_i T_i P_m} \right] \Delta p$	in. H <sub>2</sub> O	Field
(Eq. F-18) Diameter of sampling nozzle	$D_{n(\text{act})} = \sqrt{\frac{0.0358 Q_m P_m}{T_m C_p (1 - B_{ws(\text{act})})}} \sqrt{\frac{T_i M_i}{P_i \Delta p_{\text{act}}}}$	in.	Field
(Eq. F-19) % Isokinetic intermediate	$\%I_{int} = 100 \frac{T_s V_{m(std)} P_{std}}{T_{std} v_s A_n P_s 60 (1 - B_{ws(\text{act})})}$ $= K_4 \frac{T_s V_{m(std)}}{P_s v_s A_n \theta (1 - B_{ws(\text{act})})}$ Where: $K_4 = 0.09450$	Percent (dimensionless)	Field

# Method 5

Table F-4. Method 5: Report Calculations			
	Calculations	Units	Program
(Eq. F-20) Particulate matter concentration corrected to standard conditions (dry basis)	$c_s = \frac{m}{V_{std}} (2.205 \times 10^{-6})$	lb/ft <sup>3</sup>	Report
(Eq. F-21) % Isokinetic final	$\%I_{final} = \frac{100 T_{std} [K_3 V_{lc} + (V_{m(is)}/T_{m(avg)}) (P_{bar} + \frac{\Delta H}{13.6})]}{60 \theta v_{s(avg)} P_s A_n}$ <p>Where: <math>K_3 = 0.00269</math>  <math>A_n = \left(\frac{\pi}{144}\right) \left(\frac{D_n^2(act)}{4}\right)</math></p>	Percent (dimensionless)	Report
(Eq. F-22) Pollutant mass rate	$pmr = c_s Q_{slu(avg)}$	lb/hr	Report
(Eq. F-23) Emission rate	$E = c_s F_d \frac{20.9}{(20.9 - \%O_2)}$	lb/10 <sup>6</sup> Btu	Report

Now, as a review, Figure 1-1 is reproduced here with the associated symbols given for each part of the Method 5 apparatus (Figure A2-1).

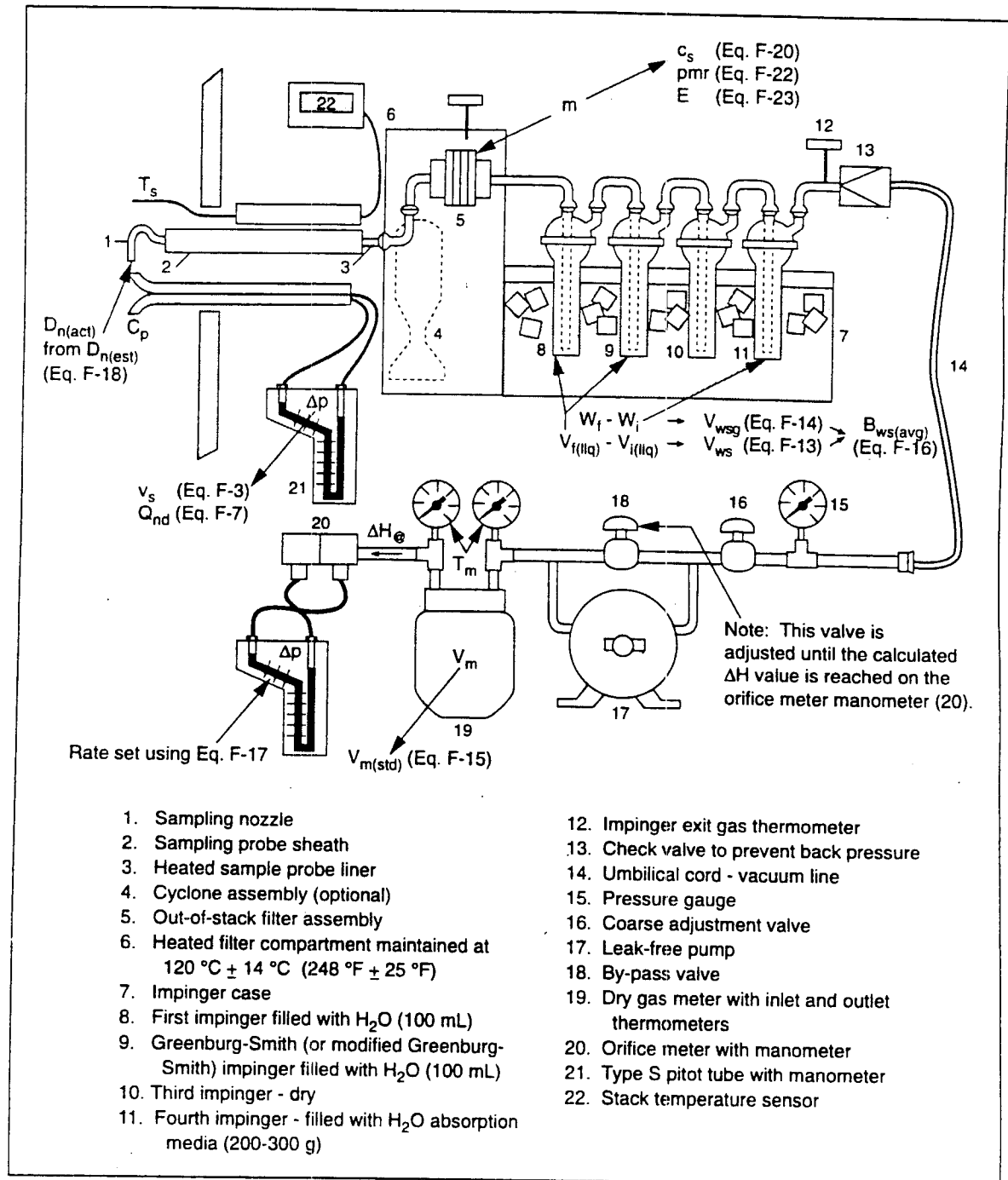

Figure F-1. Method 5 particulate sampling train (with symbols)



# ***Appendix G***

## ***Conversion Factors***



**Table G-1. Temperature**

$K = ^\circ C + 273.16$ $R = ^\circ F + 459.40$ $^\circ C = 5/9 (^{\circ}F - 32)$ $^\circ F = 9/5 (^{\circ}C) + 32$
--

Conversion from ppm to g/m<sup>3</sup> at standard conditions (20°C)

$$T_{std} = 273.15^{\circ}K$$

$$P_{std} = 1 \text{ atm}$$

$$\frac{\text{g}}{\text{dscm}} = \frac{\text{ppm} \times M \left( \frac{\text{g}}{\text{g-mole}} \right)}{22.414 \left( \frac{\text{liters}}{\text{g-mole}} \right) \times 10^3 \frac{\text{M}^3}{\text{liters}} \left( \frac{293.15^{\circ}K}{273.15^{\circ}K} \right)} \times \frac{1}{1 \times 10^6 \text{ ppm}}$$

**Table G-2. Length, Area, Volume**

Multiply	By	To Obtain
Centimeters	0.3937	Inches
Cubic feet	2.832 × 10 <sup>4</sup>	Cubic centimeters
Cubic feet	1728	Cubic inches
Cubic feet	0.02832	Cubic meters
Cubic feet	0.03704	Cubic yards
Cubic feet	28.2	Liters
Cubic meters	35.31	Cubic feet
Feet	30.48	Centimeters
Feet	0.3048	Meters
Liters	0.2642	Gallons
Meters	3.281	Feet
Meters	39.37	Inches
Square feet	0.09290	Square meters
Square meters	10.76	Square feet

**Table G-3. Flow**

Multiply	By	To Obtain
Liters/minute	5.886 × 10 <sup>-4</sup>	Cubic feet/second

**Table G-4. Mass, Pressure, Temperature, Concentration**

Multiply	By	To Obtain
Atmospheres	29.92	Inches of mercury
Atmospheres	33.90	Feet of water
Atmospheres	14.70	Pounds/square inch
Feet of water	0.02947	Atmospheres
	0.04335	Pounds/square inch
	62.378	Pounds/square foot
Inches of mercury	0.03342	Atmospheres
	13.60	Inches of water
	1.133	Feet of water
	0.4912	Pounds/square inch
	70.727	Pounds/square foot
	345.32	Kilograms/square meter
Inches of water	0.03609	Pounds/square inch
	5.1981	Pounds/square foot
	25.38	Kilograms/square meter
Kilograms/square centimeter	0.9678	Atmospheres
	14.22	Pounds/square foot
Kilograms/square meter	0.00142	Pounds/square inch
	0.20482	Pounds/square foot
	0.00328	Feet of water
	0.1	Grams/square centimeter
Kilograms	2.2046	Pounds
Pounds	453.5924	Grams
Pounds of water	0.01602	Cubic feet
Pounds of water	0.1198	Gallons
Pounds/square inch	0.06804	Atmospheres
Pounds/square inch	2.307	Feet of water
Pounds/square inch	70.31	Grams/square centimeter
Pounds/square inch	2.036	Inches of mercury
Tons (metric)	2205	Pounds
Tons (short)	0.89287	Tons (long)
Tons (short)	0.9975	Tons (metric)

**Table G-5. Viscosity**

Multiply	By	To Obtain
Poise	1.0	Gm/centimeter second
	1.0	Dyne second/centimeter squared
	100	Centipoise
Centipoise	0.000672	Pounds/foot second
	0.0000209	Pounds/second square foot
	2.42	Pounds/foot hour

**Table G-6. Density**

Multiply	By	To Obtain
Gram per cubic centimeter	62.428	Pounds/cubic feet
	0.03613	Pounds/cubic inch
Gram-moles of ideal gas at 0° C and 760 mmHg	22.4140	Liters
Pounds per cubic inch	1728	Pounds/cubic feet
	27.68	Grams/cubic centimeter
Pound-moles of ideal gas at 0° C and 760 mmHg	359.05	Cubic feet
Grams/liter	8.345	Pounds/1000 gallons
Grams/liter	0.062427	Pounds/cubic feet



